

PLUMMER BLOCKS AND ACCESSORIES – SNN SERIES AND SD SERIES

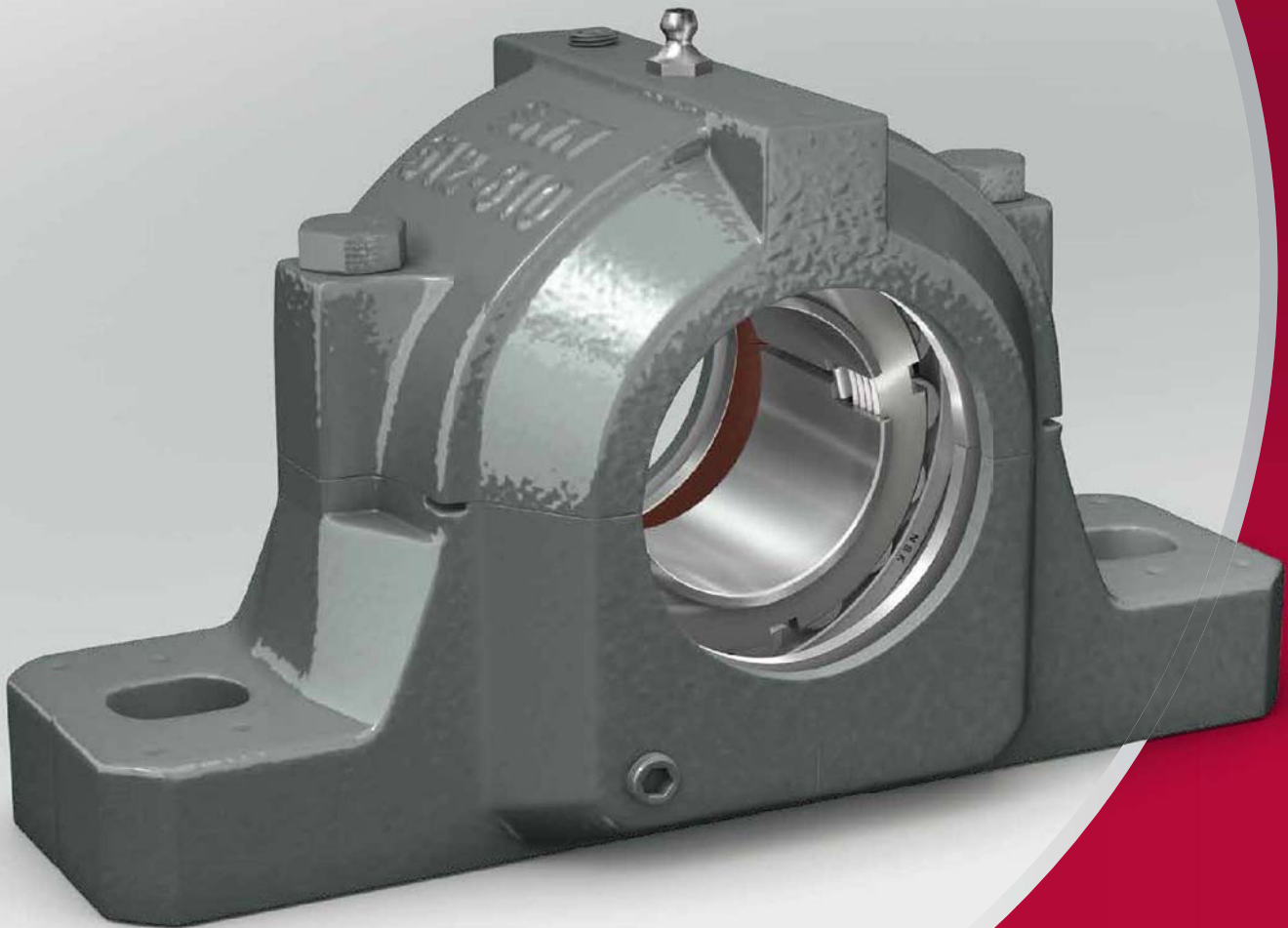

As one of the world's leading manufacturers of rolling bearings, linear technology components and steering systems, we can be found on almost every continent – with production facilities, sales offices and technology centres – because our customers appreciate short decision-making channels, prompt deliveries and local service.



The NSK company

NSK commenced operations as the first Japanese manufacturer of rolling bearings back in 1916. Ever since, we have been continuously expanding and improving not only our product portfolio but also our range of services for various industrial sectors. In this context, we develop technologies in the fields of rolling bearings, linear systems, components for the automotive industry and mechatronic systems. Our research and production facilities in Europe, Americas and Asia are linked together in a global technology

network. Here we concentrate not only on the development of new technologies, but also on the continuous optimisation of quality – at every process stage.

Among other things, our research activities include product design, simulation applications using a variety of analytical systems and the development of different steels and lubricants for rolling bearings.

Partnership based on trust – and trust based on quality

Total Quality by NSK: The synergies of our global network of NSK Technology Centres. Just one example of how we meet our requirements for high quality.

NSK is one of the leading companies with a long tradition in patent applications for machine parts. In our worldwide research centres, we not only concentrate on the development of new technologies, but also on the continual improvement

of quality based on the integrated technology platform of tribology, material technology, analysis and mechatronics.

More about NSK at www.nsk europe.com or call us on +44 (0)1636 605 123



Content





Content

SNN Series Plummer Blocks – Design	6
Modular SNN Housing Range	8
Housing Features – Designation	10
Typical Arrangements of Plummer Blocks.....	11
Breaking Loads for SNN Housings.....	12
Cap & Fixing Bolts Sizes – Recommended Tightening Torques	13
SNN Standard Sealing Arrangements	14
4 Bolt Fixing Holes / Locating Pin Holes – Recommended Dimensions.....	16
V Seals Securing Rings – Recommended Dimensions.....	17
Relationship between Circumferential and Rotational Speed.....	18
Plummer Blocks SD 3100 Series - Bolt Size and Breaking Loads	19
Dimensions – Shaft Diameter 20-65 mm	20
Dimensions – Shaft Diameter 70-140 mm.....	22
Plummer Blocks SD 3100 Series.....	24
Plummer Blocks SNN and SD 3100 Series	26
Accessories	26
Adapter Sleeve	27
Lock Nuts	29
Washer	30
Interchange List.....	31
Maintenance.....	40
Lubrication.....	41
Mounting of Spherical Roller Bearings	42
on Adapter Sleeves	42
on an Adapter Sleeve using the Axial Drive-Up Method.....	43
Radial Internal Clearance	44
Mounting of Self-Aligning Ball Bearings on Adapter Sleeves	45
Mounting of SNN Plummer Blocks.....	47
using “G” Seals.....	47
using “C” Seals	48
using “V” Seals.....	49
using “TS-U” Seals	50
using “TACK” Seals.....	51

SNN Series Plummer Blocks

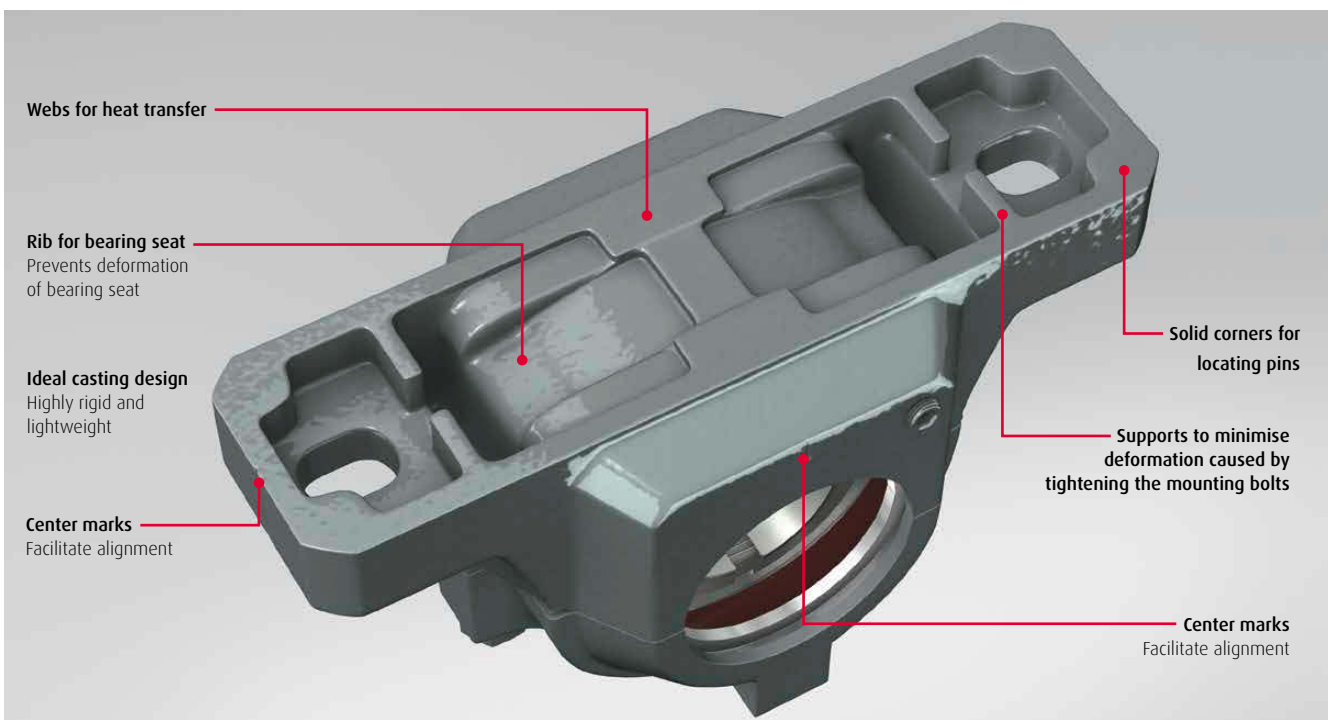
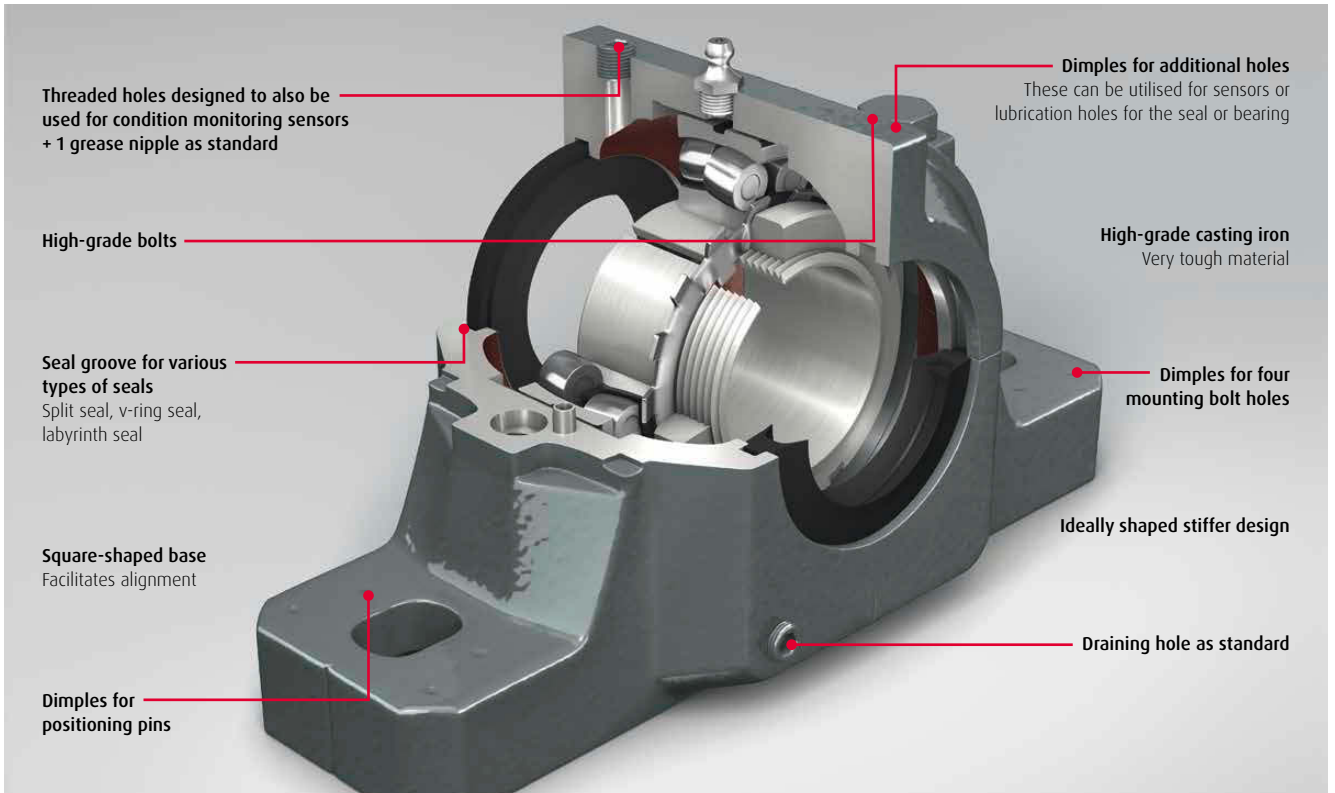



High-performance SNN Series plummer blocks are highly rigid and easy to handle. They can be equipped with NSK's tough spherical roller bearings, which have high load capacity, low temperature rise and high-strength cages.

The SNN range of split plummer blocks is the latest technical evolution from NSK

Whatever your application and whichever sector you work in (cement, mining and quarrying, air treatment, water treatment, conveying equipment, crushing equipment, etc.), you will find that NSK's SNN split housing range and bearings offer the best solution for your specific needs.

Easy and convenient mounting

- › Solid corners in the base for locating pins
- › Free surface provided for drain holes
- › Threaded hole for grease nipple
- › Dimples for additional holes
- › Square-shaped base and center marks to facilitate alignment
- › Dimples for four mounting bolt holes

Performance

- › High rigidity (minimises deformation of the bearing seat)
- › Webs for heat transfer
- › Both grease and oil lubrication are possible
- › Large oil bath
- › The same plummer block can be used with both double row self-aligning ball bearings 12xxK, 22xxK, 23xxK and spherical roller bearings in the 222xx and 223xx series

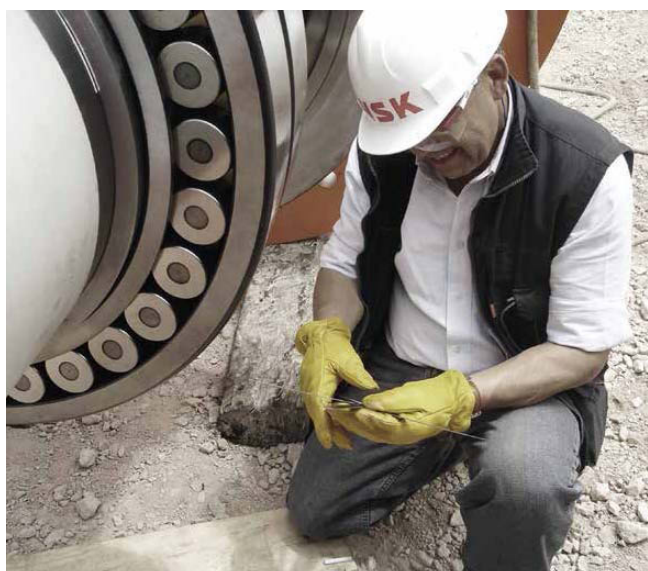

Modular SNN Housing Range

Our modular SNN housing range offers various technical options to match the needs of the most demanding applications. The components are easy to fit, remove and maintain. Equipped with NSK high performance bearings, SNN split housings will support you in achieving your cost reduction plans. Same housing can be used with both double row self-aligning ball bearings or NSKHPS double row spherical roller bearings

NSKHPS Spherical Roller Bearings

Pressed Steel Cage (EA-series)

- › Higher limiting speeds – up to 20% max.
- › Special surface treatment
- › Bore diameter available up to 130 mm

Solid Brass Cage (CAM-series)

- › Higher limiting speeds – up to 20% max.
- › Bore diameter available from 95 mm

Rollers

- › Optimised Surfaces

Long operating life and reduced maintenance costs
NSKHPS spherical roller bearings achieve an operating life twice as long as that of conventional spherical roller bearings; enabling longer machine running times and lower maintenance costs.

High rotational speeds for various applications
Due to the improved cage characteristics and their optimised internal construction, NSKHPS spherical roller bearings are particularly resistant to wear, even at high rotational speeds and over long running periods. Making them suitable for a wide range of applications.

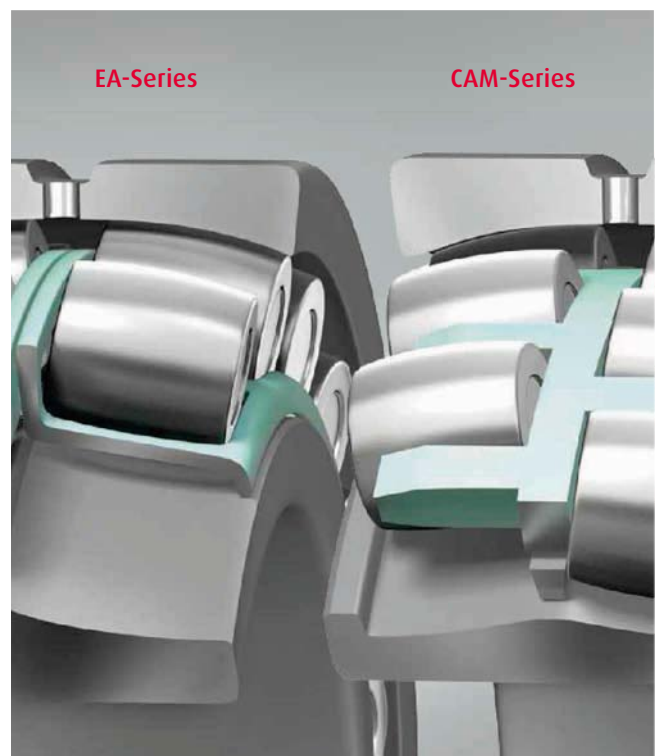

Self Aligning Ball Bearings

- › Double row bearings with a spherical outer ring raceway
- › Angle adjustment
- › Suitable for compensating for angular misalignment
- › Cylindrical and tapered bores
- › Cages of these bearings are normally made of glass-fibre reinforced Polyamide 66

Standards, dimensions

The external dimensions of Self Aligning Ball Bearings are laid down in ISO R15 or DIN 630.

Tolerances

The bearings are only manufactured to the standard tolerance P0.

Bearing clearance

Self Aligning Bearings with cylindrical bores are normally manufactured with standard radial clearance C0 and those with a tapered bore with radial clearance C3. Bearings with other clearances are available on enquiry.



Typical Arrangements of Plummer Blocks

Plummer blocks typical arrangement

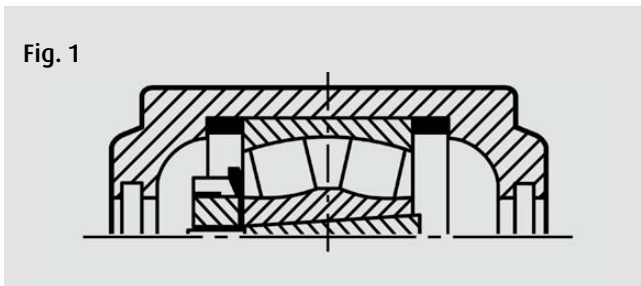

Fig.1:
In the fixed plummer block, to prevent axial displacement of the bearing, 2 locating rings are installed, one on either side of the bearing. Locating rings are manufactured in aluminium.

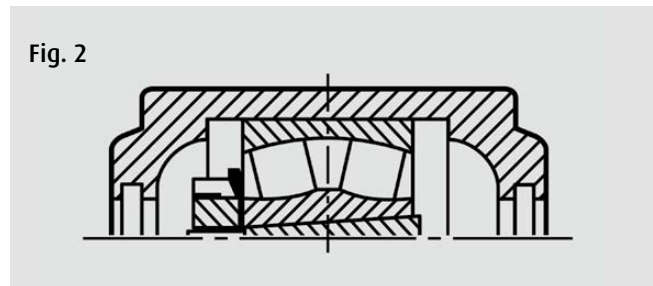

Fig.2:
One bearing should be free to move axially. This plummer block should not be assembled with locating rings.

How to order SNN complete Plummer Blocks from NSK

Example 1 – Application with 2 plummer blocks

Free end

Through shaft diam 50 mm, equipped with 1 spherical roller bearing 22211EAK, double lip seals on both sides.

Parts required:

- › 1 NSK housing SNN511-609
- › 1 NSK bearing 22211EAKE4
- › 1 NSK adapter sleeve H311
- › 1 seal pack G511-KIT (2 seals included)

Fixed end

Shaft end, diam 50 mm, equipped with 1 spherical roller bearing 22211EAK, double lip seal on 1 side.

Parts required:

- › 1 NSK housing SNN511-609
- › 1 NSK bearing 22211EAKE4
- › 1 NSK adapter sleeve H311
- › 1 locating ring kit SR100/9.5-KIT (2 rings included)
- › 1 seal pack G511-KIT (2 seals included)
- › 1 end cover 511A

Example 2 – Application with 2 plummer blocks

Free end

Through shaft diam 75 mm, equipped with 1 spherical roller bearing 22217EAK, labyrinth seals on both sides.

Parts required:

- › 1 NSK housing SNN517
- › 1 NSK bearing 22217EAKE4
- › 1 NSK adapter sleeve H317
- › 2 seals TS517U (the kit includes 1 labyrinth and o-ring)

Fixed end

Shaft end, diam 75 mm, equipped with 1 spherical roller bearing 22217EAK, labyrinth seal on 1 side.

Parts required:

- › 1 NSK housing SNN517
- › 1 NSK bearing 22217EAKE4
- › 1 NSK adapter sleeve H317
- › 1 locating ring kit SR150/12.5-KIT (2 rings included)
- › 1 seal TS517U (the kit includes 1 labyrinth and o-ring)
- › 1 end cover 517A

Breaking Loads for SNN Housings

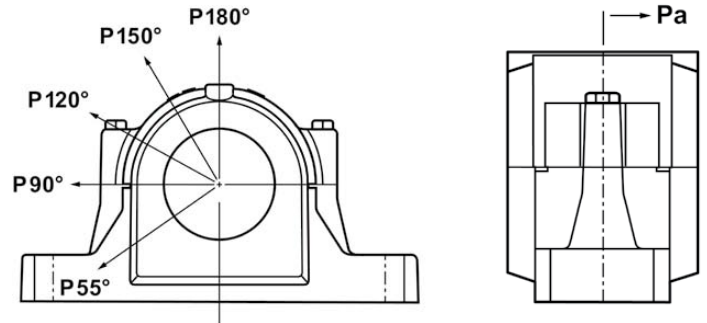

Housing No.		Breaking Load (kN)						Max. Loads of the two cap bolts (kN)
		Pa	P55°	P90°	P120°	P150°	P180°	P180°
SNN	505	52	155	95	70	60	80	25
SNN	506-605	55	170	100	80	65	85	25
SNN	507-606	60	190	115	85	80	95	25
SNN	508-607	70	215	130	95	85	110	25
SNN	509	75	230	140	100	90	115	25
SNN	510-608	85	265	155	120	110	130	25
SNN	511-609	90	275	170	125	115	140	40
SNN	512-610	100	300	180	130	120	150	40
SNN	513-611	110	340	205	150	130	170	40
SNN	515-612	135	410	250	185	160	205	40
SNN	516-613	140	430	260	190	175	215	40
SNN	517	155	480	290	205	190	240	40
SNN	518-615	180	550	340	250	215	275	85
SNN	519-616	190	580	350	260	230	290	85
SNN	520-617	200	620	370	280	250	310	130
SNN	522-619	220	680	410	310	275	340	130
SNN	524-620	260	790	470	350	320	400	130
SNN	526	295	900	540	410	360	450	190
SNN	528	345	1050	630	470	430	530	190
SNN	530	390	1200	730	540	480	600	190
SNN	532	470	1450	860	640	570	720	190

Cap bolt material: Grade 8.8
Reference values only

Cap & Fixing Bolts Sizes – Recommended Tightening Torques

SNN Housing	Cap Bolt Size Grade 8.8	Recommended max. Tightening Torque	Base Bolts Size Grade 8.8	Recommended max. Tightening Torque
		Nm		Nm
SNN505	M10	50	M12	80
SNN506-605	M10	50	M12	80
SNN507-606	M10	50	M12	80
SNN508-607	M10	50	M12	80
SNN509	M10	50	M12	80
SNN510-608	M10	50	M12	80
SNN511-609	M12	80	M16	200
SNN512-610	M12	80	M16	200
SNN513-609	M12	80	M16	200
SNN515-612	M12	80	M16	200
SNN516-613	M16	150	M20	385
SNN517	M16	150	M20	385
SNN518-615	M16	150	M20	385
SNN519-616	M16	150	M20	385
SNN520-617	M20	200	M24	665
SNN522-619	M20	200	M24	665
SNN524-620	M20	200	M24	665
SNN526	M24	350	M24	665
SNN528	M24	350	M30	1310
SNN530	M24	350	M30	1310
SNN532	M24	350	M30	1310

SNN Standard Sealing Arrangements

There are several different types of seal designs for the use in SNN housings. Many alternative choices are available to the user to ensure that the most suitable solution will be found to meet a wide range of application conditions.



G Seals



C Seals

Seal Type	G Type	C Type
Material	NBR	Mild steel + Wool & Rayon
Temperature	-35°C to +80°C	-40°C to +100°C
Max. Speed	5m/s (1)	4m/s
Max. Misalignment	0.5 to 1°	up to 0.5°
Grease Lubrication	Excellent	Good
Low Friction Torque	Good	Poor
Axial Shaft Displacement	Excellent	Excellent
Performance when exposed to:		
Dust	Excellent	Excellent
Large Particles	Good	Good
Water	Good	Fair
	4 halves, to equip both sides of the housing	4 NBR o-rings, 4 halves/steel adapters, 4 felt strips, to equip both sides of housing

Remarks

- (1) With grease lubrication
- (2) Up to 12m/s with v-ring securing ring
- (3) Depends on shaft diameter



V Seals

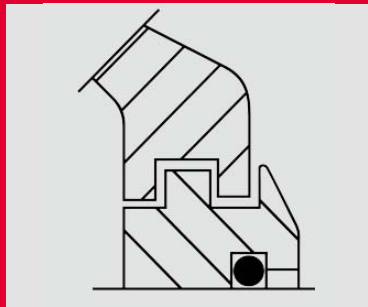

TS-U Seals

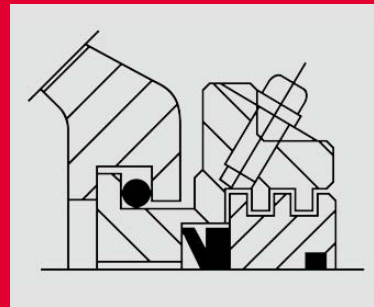

TACK Seals

	V Type	TS-U Type	TACK Type
	Mild steel & NBR	Cast Iron + NBR	Cast Iron + NBR
	-20°C to +100°C	-40°C to +120°C	-40°C to +100°C
	7m/s (2)	Same as Bearing	7m/s (3)
	1 to 1.5°	up to 0.3°	up to 0.5°
	Excellent	Good	Good
	Good	Excellent	Good
	Poor	Fair	Poor
Performance when exposed to:			
	Excellent	Good	Excellent
	Poor	Good	Good
	Good	Poor	Good
	2 NBR v-rings, mild steel + NBR plates, to equip both sides of the housing	1 cast iron labyrinth + 1 NBR o-ring, to equip 1 side of the housing	1 cast iron labyrinth 2 NBR o-ring, 1 NBR v-ring, 1 cast iron body and 1 grease nipple, to equip 1 side of the housing

Note

End cover A (designation example: 509A) are supplied as a single item in a plastic bag (1 NBR + Mild steel plate to equip 1 side of the housing)
Seals for high temperature applications can be supplied on request. For more information, please consult NSK.

4 Bolt Fixing Holes / Locating Pin Holes – Recommended Dimensions

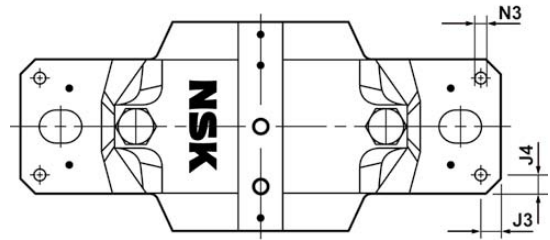
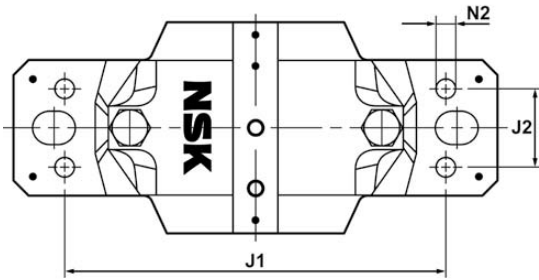

Recommended Dimensions for 4-Bolt Fixing Holes (mm)

Housing No.	J1	J2	N2	Bolt Size
SNN508-607	160	34	11	M10
SNN509	160	34	11	M10
SNN510-608	160	34	11	M10
SNN511-609	200	40	14	M12
SNN512-610	200	40	14	M12
SNN513-611	210	48	14	M12
SNN515-612	220	48	14	M12
SNN516-613	244	52	18	M16
SNN517	254	52	18	M16
SNN518-615	275	58	18	M16
SNN519-616	275	58	18	M16
SNN520-617	300	66	18	M16
SNN522-619	320	74	18	M16
SNN524-620	320	74	18	M16
SNN526	355	84	22	M20
SNN528	400	92	26	M24
SNN530	430	100	26	M24
SNN532	450	100	26	M24

Recommended Dimensions for Locating Pin Holes (mm)

Housing No.	J3	J4	N3 Max
SNN505	7	7	6
SNN506-605	8	8	6
SNN507-606	8	8	6
SNN508-607	9	9	8
SNN509	9	9	8
SNN510-608	9	9	8
SNN511-609	10	10	10
SNN512-610	10	10	10
SNN513-611	12	12	10
SNN515-612	12	12	10
SNN516-613	15	15	12
SNN517	15	15	12
SNN518-615	15	15	12
SNN519-616	15	15	12
SNN520-617	15	15	12
SNN522-619	18	18	16
SNN524-620	18	18	16
SNN526	18	18	16
SNN528	18	18	16
SNN530	18	18	16
SNN532	18	18	16

V Seals Securing Rings – Recommended Dimensions

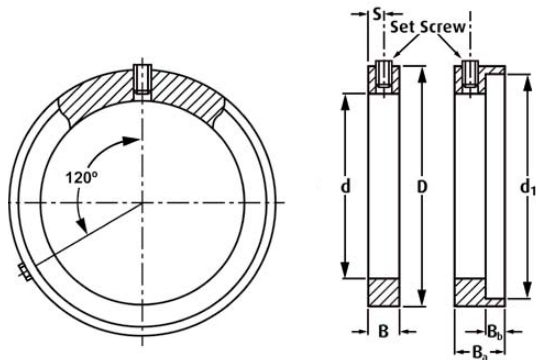

Shaft Diameter	d (H7)	D	B	B _a	B _b	d ₁	S	Set Screw
mm	mm	mm	mm	mm	mm	mm	mm	Din913
20	20	30.0	6	9.5	3.5	27.2	3.0	M3
25	25	35.0	6	9.5	3.5	32.1	3.0	M3
30	30	40.0	6	9.5	3.5	37.2	3.0	M3
35	35	45.0	6	9.5	3.5	42.2	3.0	M3
40	40	53.0	8	12.5	4.5	49.1	4.0	M4
45	45	58.0	8	12.5	4.5	54.0	4.0	M4
50	50	63.0	8	12.5	4.5	59.1	4.0	M4
55	55	68.0	8	12.5	4.5	64.1	4.0	M4
60	60	73.0	8	12.5	4.5	69.1	4.0	M4
65	65	78.0	8	12.5	4.5	74.1	4.0	M4
70	70	84.0	8	14.0	6.0	81.0	4.0	M4
75	75	89.5	10	16.0	6.0	86.0	5.0	M5
80	80	94.5	10	16.0	6.0	91.0	5.0	M5
85	85	100.0	10	16.0	6.0	96.0	5.0	M5
90	90	105.0	10	16.0	6.0	101.0	5.0	M5
95	95	109.0	10	16.0	6.0	106.0	5.0	M5
100	100	115.0	10	16.0	6.0	111.0	5.0	M5
110	110	128.0	11	18.5	7.5	122.9	5.5	M6
115	115	133.0	11	18.5	7.5	127.4	5.5	M6
125	125	143.0	11	18.5	7.5	138.1	5.5	M6
135	135	153.0	11	18.5	7.5	147.5	5.5	M6
140	140	158.0	11	18.5	7.5	152.9	5.5	M6
145	145	163.0	11	18.5	7.5	158.1	5.5	M6
155	155	173.0	11	19.5	8.5	167.5	5.5	M6
165	165	185.5	11	19.5	8.5	179.9	5.5	M6
175	175	195.0	11	19.5	8.5	189.3	5.5	M6

NB: not supplied by NSK

Relationship between Circumferential and Rotational Speed

Shaft Diameter (mm)	Circumferential Speed			
	4 m/s	5 m/s	7 m/s	12 m/s
	Corresponding Rotational Speed min-1			
20	3820	4775	6685	11460
25	3060	3825	5355	9170
30	2550	3188	4463	7640
35	2180	2725	3815	6550
40	1910	2388	3343	5730
45	1700	2125	2975	5090
50	1530	1913	2678	4580
55	1390	1738	2433	4170
60	1270	1588	2223	3820
65	1180	1475	2065	3530
70	1090	1363	1908	3270
75	1020	1275	1785	3060
80	950	1188	1663	2860
85	900	1125	1575	2700
90	850	1063	1488	2550
95	800	1000	1400	2410
100	760	950	1330	2290
110	690	863	1208	2080
115	660	825	1155	1990
120	640	800	1120	1910
125	610	763	1068	1830
130	590	738	1033	1760
135	570	713	998	1700
140	550	688	963	1640
145	530	663	928	1580
150	510	638	893	1530
155	490	613	858	1480
165	460	575	805	1390
175	440	550	770	1310

Plummer Blocks SD 3100 Series

Bolt Size and Breaking Loads

Plummer blocks of series SD3100 are used with large spherical roller bearings of series 23100 with tapered bore on adapter sleeves.

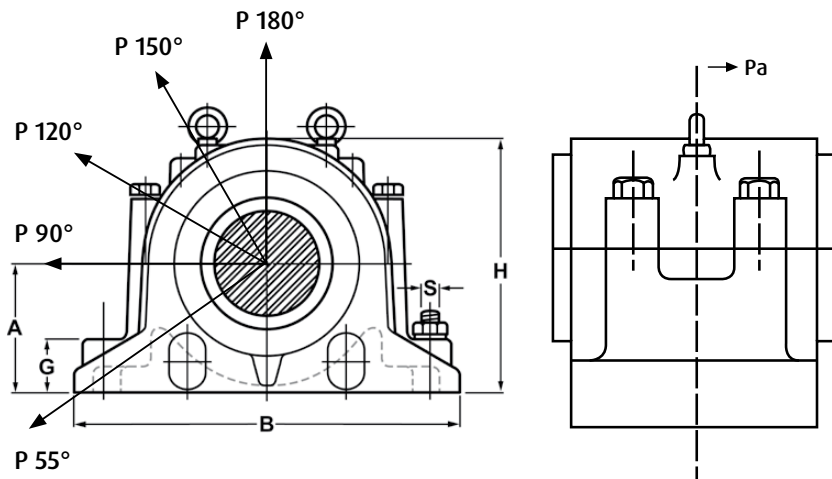

Material: Cast Iron Grade 200
Colour: Dark Blue 533C
Cap bolts grade: 8.8 (size: see table below)

Supplied with 1 straight grease nipple

Tolerance of bearing seating: H7
Draining hole: 1/4PT

SD 3100 Bolt Size

Housing	Bolt Size
SD3134TS/TAC	M20*2.5P*140LG
SD3136TS/TAC	M24*3.0P*140LG
SD3138TS/TAC	M24*3.0P*140LG
SD3140TS/TAC	M24*3.0P*170LG
SD3144TS/TAC	M24*3.0P*170LG
SD3148TS/TAC	M30*3.5P*200LG
SD3152TS/TAC	M30*3.5P*200LG
SD3156TS/TAC	M30*3.5P*210LG
SD3160TS/TAC	M30*3.5P*220LG
SD3164TS/TAC	M30*3.5P*220LG
SD3168TS/TAC	M36*4.0P*260LG
SD3172TS/TAC	M36*4.0P*280LG
SD3176TS/TAC	M36*4.0P*280LG
SD3180TS/TAC	M36*4.0P*310LG

Breaking Loads of SD Housings

Housing No.	Breaking Load (kN)					Max. Load of Cap Bolts (kN)
	P55°	P90°	P120°	P150°	P180°	P180°
SD 3134	2273	1016	762	747	846	380
SD 3136	2540	1150	850	835	946	380
SD 3138	2941	1300	1020	966	1095	380
SD 3140	3476	1600	1165	1143	1296	380
SD 3144	4280	1900	1435	1407	1594	380
SD 3148	4548	2000	1524	1495	1694	620
SD 3152	5083	2300	1703	1670	1893	620
SD 3156	5350	2400	1810	1760	1993	620
SD 3160	6420	2900	2215	2110	2390	620
SD 3164	7490	3400	2525	2400	2790	620
SD 3168	9320	4200	3260	3050	3490	800
SD 3172	9750	4400	3370	3200	3690	800
SD 3176	10230	4550	3500	3320	3710	800
SD 3180	10720	4800	3770	3560	4000	800

Reference values only

Dimensions – Shaft Diameter 20-65 mm

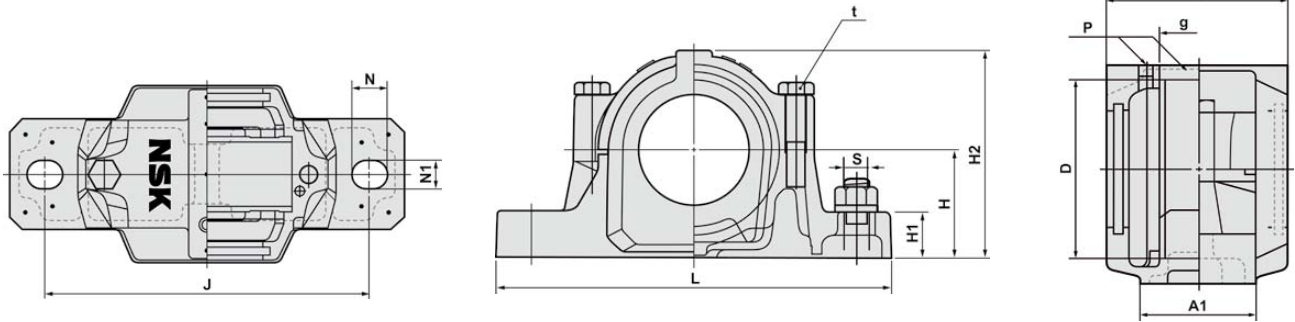

Shaft Diam. D (mm)	Bearing		Adapter Sleeve	Locating Ring Kit (2 rings)	Housing	Housing Designation	D (mm)	H (mm)	J (mm)	A (mm)	L (mm)	A1 (mm)	H1 (mm)	H2 (mm)
	Ball	Roller												
20	1205K	-	H205	SR52x5	SNN505	SNN505	52	40	130	70	165	46	22	73
	2205K	22205K	H305	SR52x3.5										
	1305K	21305K	H305	SR62x7.5	SNN605									
	2305K	-	H2305	SR62x4										
25	1206K	-	H206	SR62x8	SNN506	SNN506-605	62	50	150	80	185	52	22	88
	2206K	22206K	H306	SR62x6										
	1306K	21306K	H306	SR72x7.5	SNN606									
	2306K	-	H2306	SR72x3.5										
30	1207K	-	H207	SR72x8.5	SNN507	SNN507-606	72	50	150	85	185	52	22	93
	2207K	22207K	H307	SR72x5.5										
	1307K	21307K	H307	SR80x9	SNN607									
	2307K	-	H2307	SR80x4										
35	1208K	-	H208	SR80x10.5	SNN508	SNN508-607	80	60	170	90	205	60	25	107
	2208K	22208K	H308	SR80x8										
	1308K	21308K	H308	SR90x9	SNN608									
	2308K	22308K	H2308	SR90x4										
40	1209K	-	H209	SR85x5.5	SNN509	SNN509	85	60	170	90	205	60	25	111
	2209K	22209K	H309	SR85x3.5										
	1309K	21309K	H309	SR100x9.5	SNN609									
	2309K	22309K	H2309	SR100x4										
45	1210K	-	H210	SR90x10.5	SNN510	SNN510-608	90	60	170	95	205	60	25	113
	2210K	22210K	H310	SR90x9										
	1310K	21310K	H310	SR110x10.5	SNN610									
	2310K	22310K	H2310	SR110x4										
50	1211K	-	H211	SR100x11.5	SNN511	SNN511-609	100	70	210	100	255	70	28	129
	2211K	22211K	H311	SR100x9.5										
	1311K	21311K	H311	SR120x11	SNN611									
	2311K	22311K	H2311	SR120x4										
55	1212K	-	H212	SR110x13	SNN512	SNN512-610	110	70	210	110	255	70	30	134
	2212K	22212K	H312	SR110x10										
	1312K	21312K	H312	SR130x12.5	SNN612									
	2312K	22312K	H2312	SR130x5										
60	1213K	-	H213	SR120x14	SNN513	SNN513-611	120	80	230	115	275	80	30	150
	2213K	22213K	H313	SR120x10										
	1313K	21313K	H313	SR140x12.5	SNN613									
	2313K	22313K	H2313	SR140x5										
65	1215K	-	H215	SR130x15.5	SNN515	SNN515-612	130	80	230	120	280	80	30	155
	2215K	22215K	H315	SR130x12.5										
	1315K	21315K	H315	SR160x14	SNN615									
	2315K	22315K	H2315	SR160x5										

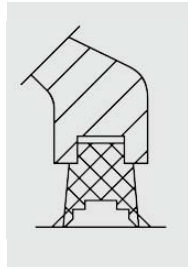

G Seals

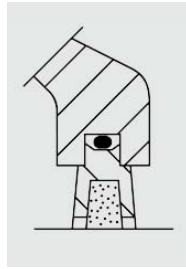

C Seals

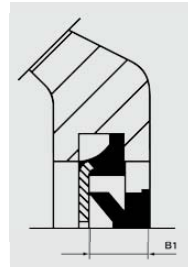

V Seals

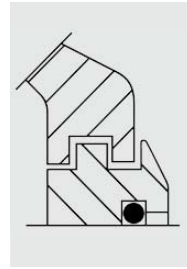

TS-U Seals

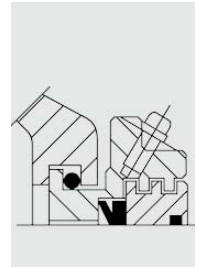

TACK Seals

	g (mm)	t (mm)	N (mm)	N1 (mm)	s (mm)	P	G Seals KIT	C Seals KIT	V Seals KIT (B1: Fitted Width)	TS-U Seals	TACK Seals	End Cover	Mass (kg)
	25	M10	20	15	M12	R1/8	G505-KIT	C505-KIT	V505-KIT (6 ±0.8)	TS505U	TACK505	505A 505A	1.45
	32	M10	20	15	M12	R1/8	G605-KIT	C605-KIT	V605-KIT (6 ±0.8)	TS605U	TACK605	505A 505A	2.00
							G506-KIT	C506-KIT	V506-KIT (6 ±0.8)	TS506U	TACK506	506A 506A	
	34	M10	20	15	M12	R1/8	G606-KIT	C606-KIT	V606-KIT (6 ±0.8)	TS606U	TACK606	507A 507A	2.20
							G507-KIT	C507-KIT	V507-KIT (6 ±0.8)	TS507U	TACK507	507A 507A	
	39	M10	20	15	M12	R1/8	G607-KIT	C607-KIT	V607-KIT (6 ±0.8)	TS607U	TACK607	508A 508A	2.90
							G508-KIT	C508-KIT	V508-KIT (6 ±0.8)	TS508U	TACK508	508A 508A	
	41	M10	20	15	M12	R1/8	G608-KIT	C608-KIT	V608-KIT (6 ±0.8)	TS608U	TACK608	510A 510A	3.10
	30	M10	20	15	M12	R1/8	G509-KIT	C509-KIT	V509-KIT (7 ±1)	TS509U	TACK509	509A 509A	3.00
	44	M12	24	18	M16	R1/8	G609-KIT	C609-KIT	V609-KIT (7 ±1)	TS609U	TACK609	511A 511A	4.80
	41	M10	20	15	M12	R1/8	G510-KIT	C510-KIT	V510-KIT (7 ±1)	TS510U	TACK510	510A 510A	3.10
							G610-KIT	C610-KIT	V610-KIT (7 ±1)	TS610U	TACK610	512A 512A	
	48	M12	24	18	M16	R1/8	G511-KIT	C511-KIT	V511-KIT (7 ±1)	TS511U	TACK511	511A 511A	4.80
	51	M12	24	18	M16	R1/8	G611-KIT	C611-KIT	V611-KIT (7 ±1)	TS611U	TACK611	513A 513A	6.60
							G512-KIT	C512-KIT	V512-KIT (7 ±1)	TS512U	TACK512	512A 512A	
	48	M12	24	18	M16	R1/8	G512-KIT	C512-KIT	V512-KIT (7 ±1)	TS512U	TACK512	512A 512A	5.40
	56	M12	24	18	M16	R1/8	G612-KIT	C612-KIT	V612-KIT (7 ±1)	TS612U	TACK612	515A 515A	6.80
							G513-KIT	C513-KIT	V513-KIT (7 ±1)	TS513U	TACK513	513A 513A	
	51	M12	24	18	M16	R1/8	G513-KIT	C513-KIT	V513-KIT (7 ±1)	TS513U	TACK513	513A 513A	6.60
	58	M16	28	22	M20	R1/4	G613-KIT	C613-KIT	V613-KIT (7 ±1)	TS613U	TACK613	516A 516A	10.20
							G515-KIT	C515-KIT	V515-KIT (7 ±1)	TS515U	TACK515	515A 515A	
	56	M12	24	18	M16	R1/8	G515-KIT	C515-KIT	V515-KIT (7 ±1)	TS515U	TACK515	515A 515A	6.80
	65	M16	28	22	M20	R1/4	G615-KIT	C615-KIT	V615-KIT (7 ±1)	TS615U	TACK615	518A 518A	13.00
							G518-KIT	C518-KIT	V518-KIT (7 ±1)	TS518U	TACK518	518A 518A	

Dimensions – Shaft Diameter 70-140 mm

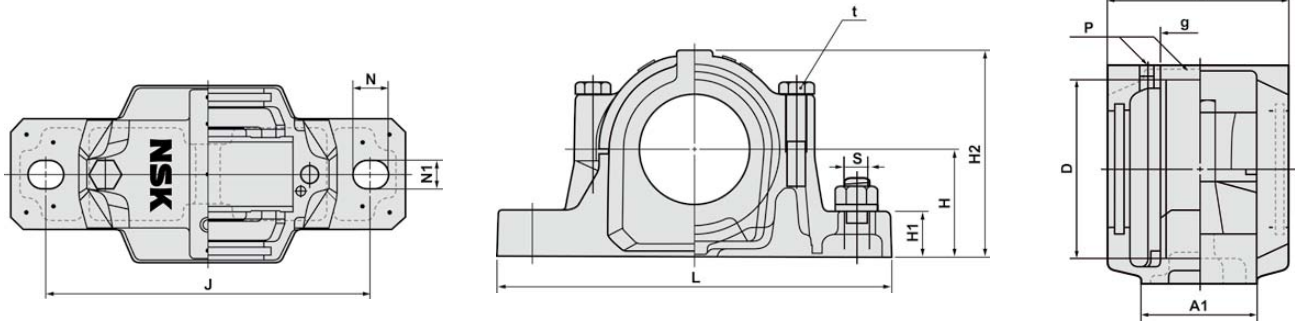

Shaft Diam. D (mm)	Bearing		Adapter Sleeve	Locating Ring Kit (2 rings)	Housing	Housing Designation	D (mm)	H (mm)	J (mm)	A (mm)	L (mm)	A1 (mm)	H1 (mm)	H2 (mm)
	Ball	Roller												
70	1216K	-	H216	SR140x16	SNN516	SNN516-613	140	95	260	130	315	90	32	175
	2216K	22216K	H316	SR140x12.5										
	1316K	21316K	H316	SR170x14.5	SNN616	SNN519-616	170	112	290	145	345	100	35	210
75	2316K	22316K	H2316	SR170x5										
	1217K	-	H217	SR150x16.5	SNN517	SNN517	150	95	260	135	320	90	32	183
	2217K	22217K	H317	SR150x12.5										
	1317K	21317K	H317	SR180x14.5	SNN617	SNN520-617	180	112	320	160	380	110	40	215
	2317K	22317K	H2317	SR180x5										
80	1218K	-	H218	SR160x17.5	SNN518	SNN518-615	160	100	290	145	345	100	35	193
	2218K	22218K	H318	SR160x12.5										
	-	23218K	H2318	SR160x6.25										
85	1219K	-	H219	SR170x18	SNN519	SNN519-616	170	112	290	145	345	100	35	210
	2219K	22219K	H319	SR170x12.5										
	1319K	21319K	H319	SR200x17.5	SNN619	SNN522-619	200	125	350	175	410	120	45	240
	2319K	22319K	H2319	SR200x6.5										
90	1220K	-	H220	SR180x18	SNN520	SNN520-617	180	112	320	160	380	110	40	215
	2220K	22220K	H320	SR180x12										
	-	23220K	H2320	SR180x4.75										
	1320K	21320K	H320	SR215x19.5	SNN620	SNN524-620	215	140	350	185	410	120	45	271
100	2320K	22320K	H2320	SR215x6.5										
	1222K	-	H222	SR200x21	SNN522	SNN522-619	200	125	350	175	410	120	45	240
	2222K	22222K	H322	SR200x13.5										
110	-	23222K	H2322	SR200x5										
	-	22224K	H3124	SR215x14	SNN524	SNN524-620	215	140	350	185	410	120	45	271
115	-	23224K	H2324	SR215x5										
	-	22226K	H3126	SR230x13	SNN526	SNN526	230	150	380	190	445	130	50	288
125	-	23226K	H2326	SR230x5										
	-	22228K	H3128	SR250x15	SNN528	SNN528	250	150	420	205	500	150	50	298
	-	23228K	H2328	SR250x5										
135	-	22230K	H3130	SR270x16.5	SNN530	SNN530	270	160	450	220	530	160	60	322
	-	23230K	H2330	SR270x5										
140	-	22232K	H3132	SR290x17	SNN532	SNN532	290	170	470	235	550	160	60	342
	-	23232K	H2332	SR290x5										

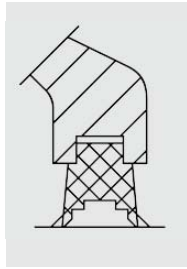

G Seals

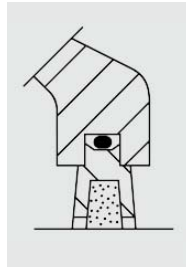

C Seals

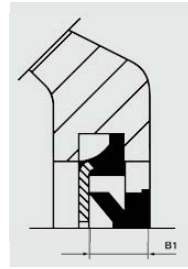

V Seals

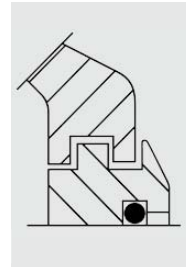

TS-U Seals

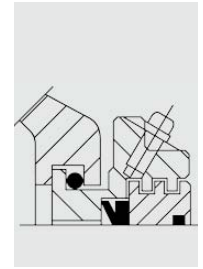

TACK Seals

	g (mm)	t (mm)	N (mm)	N1 (mm)	s (mm)	P	G Seals KIT	C Seals KIT	V Seals KIT (B1: Fitted Width)	TS-U Seals	TACK Seals	End Cover	Mass (kg)
	58	M16	28	22	M20	R1/4	G516-KIT	C516-KIT	V516-KIT (9 ±1.2)	TS516U	TACK516	516A	10.20
	68	M16	28	22	M20	R1/4	G616-KIT	C616-KIT	V616-KIT (9 ±1.2)	TS616U	TACK616	519A	14.50
	61	M16	28	22	M20	R1/4	G517-KIT	C517-KIT	V517-KIT (9 ±1.2)	TS517U	TACK517	517A	11.20
	70	M20	32	22	M24	R1/4	G617-KIT	C617-KIT	V617-KIT (9 ±1.2)	TS617U	TACK617	520A	18.30
	65	M16	28	26	M20	R1/4	G518-KIT	C518-KIT	V518-KIT (9 ±1.2)	TS518U	TACK518	518A	13.00
	68	M16	28	22	M20	R1/4	G519-KIT	C519-KIT	V519-KIT (9 ±1.2)	TS519U	TACK519	519A	14.50
	80	M20	32	26	M24	R1/4	G619-KIT	C619-KIT	V619-KIT (9 ±1.2)	TS619U	TACK619	522A	24.00
	70	M20	32	26	M24	R1/4	G520-KIT	C520-KIT	V520-KIT (9 ±1.2)	TS520U	TACK520	520A	18.30
	86	M20	32	26	M24	R3/8	G620-KIT	C620-KIT	V620-KIT (9 ±1.2)	TS620U	TACK620	524A	26.20
	80	M20	32	26	M24	R1/4	G522-KIT	C522-KIT	V522-KIT (9 ±1.2)	TS522U	TACK522	522A	24.00
	86	M20	32	26	M24	R3/8	G524-KIT	C524-KIT	V524-KIT (9 ±1.2)	TS524U	TACK524	524A	26.20
	90	M24	35	28	M24	R3/8	G526-KIT	C526-KIT	V526-KIT (9 ±1.2)	TS526U	TACK526	526A	33.00
	98	M24	42	35	M30	R3/8	G528-KIT	C528-KIT	V528-KIT (9 ±1.2)	TS528U	TACK528	528A	40.00
	106	M24	42	35	M30	R3/8	G530-KIT	C530-KIT	V530-KIT (9 ±1.2)	TS530U	TACK530	530A	49.00
	114	M24	42	35	M30	R3/8	G532-KIT	C532-KIT	V532-KIT (9 ±1.2)	TS532U	TACK532	532A	55.00

Plummer Blocks SD 3100 Series

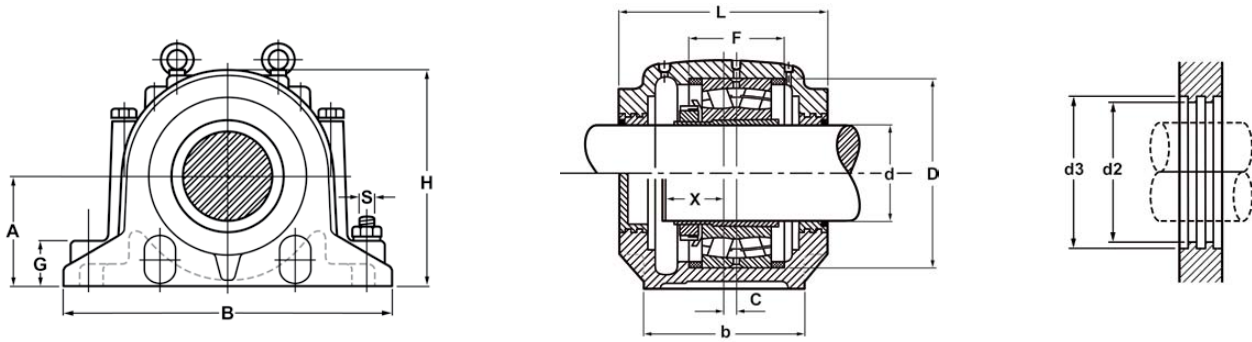

Housing	Shaft Diameter (d)		Dimensions mm																	
	Metric	Inch	D	d2 (H12)	d3 (H12)	A	B	F	E	b	G	H	L	C	E1	X	T	Z	U	V
SD3134	150	6	280	187	197	170	510	108	430	180	70	335	230	14	100	76	154	120	28	35
SD3136	160	6.1/2	300	195	205	180	530	116	450	190	75	355	240	15	110	81	159	130	30	38
SD3138	170	6.3/4	320	217	230	190	560	124	480	210	80	375	260	10	120	86	168	140	35	48
SD3140	180	7	340	222	237	210	610	132	510	230	85	410	280	10	130	91	178	150	35	42
SD3144	200	8	370	246	265	220	640	140	540	240	90	435	290	12	140	96	184	155	36	46
SD3148	220	9	400	265	285	240	700	148	600	260	95	475	310	12	150	102	194	160	38	46
SD3152	240	9.1/2	440	285	305	260	770	164	650	280	100	515	320	13	160	112	200	170	45	60
SD3156	260	10	460	307	327	280	790	166	670	280	105	550	330	16	160	115	200	170	45	60
SD3160	280	11	500	325	345	300	830	180	710	310	110	590	350	22	190	124	213	190	45	64
SD3164	300		540	345	365	320	880	196	750	330	115	630	370	23	200	135	224	200	45	72
SD3168	320		580	368	390	340	965	210	840	380	120	670	390	25	240	155	244	220	52	70
SD3172	340		600	388	408	360	1040	212	890	390	130	720	400	22	255	159	249	225	60	77
SD3176	360		620	408	428	380	1120	214	980	400	135	750	405	22	255	162	260	240	68	88
SD3180	380		650	428	448	400	1245	220	1050	420	140	790	425	22	270	167	276	260	75	96

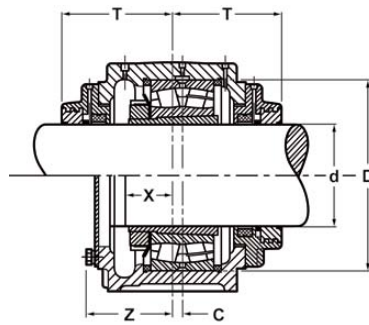
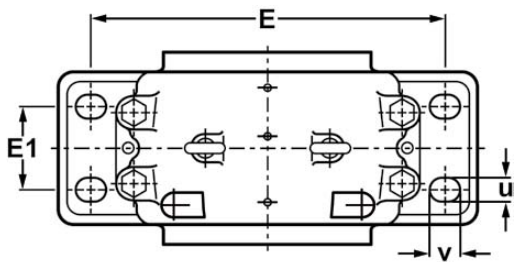

	Bolt Diameter	Spherical Roller Bearing	Adapter Sleeve		Weight kg	Locating Ring Kit (2 rings)	Housing	Labyrinth Seal	End Cover
	S		Metric	Inch					
	M24	23134K	H3134	HE3134	66	FR 280/10	SD3134	TS34	TSA34
	M24	23136K	H3136	HE3136	75	FR 300/10	SD3136	TS36	TSA36
	M24	23138K	H3138	HE3138	87	FR 320/10	SD3138	TS38	TSA38
	M30	23140K	H3140	HE3140	113	FR 340/10	SD3140	TS40	TSA40
	M30	23144K	H3144		129	FR 370/10	SD3144	TS44	TSA44
	M30	23148K	H3148		163	FR 400/10	SD3148	TS48	TSA48
	M36	23152K	H3152		199	FR 440/10	SD3152	TS52	TSA52
	M36	23156K	H3156		226	FR 460/10	SD3156	TS56	TSA56
	M36	23160K	H3160		283	FR 500/10	SD3160	TS60	TSA60
	M36	23164K	H3164		346	FR 540/10	SD3164	TS64	TSA64
	M36	23168K	H3168		514	FR 580/10	SD3168	TS68	TSA68
	M48	23172K	H3172		594	FR 600/10	SD3172	TS72	TSA72
	M56	23176K	H3176		702	FR 620/10	SD3176	TS76	TSA76
	M64	23180K	H3180		740	FR 650/10	SD3180	TS80	TSA80

Plummer Blocks SNN and SD 3100 Series

Accessories

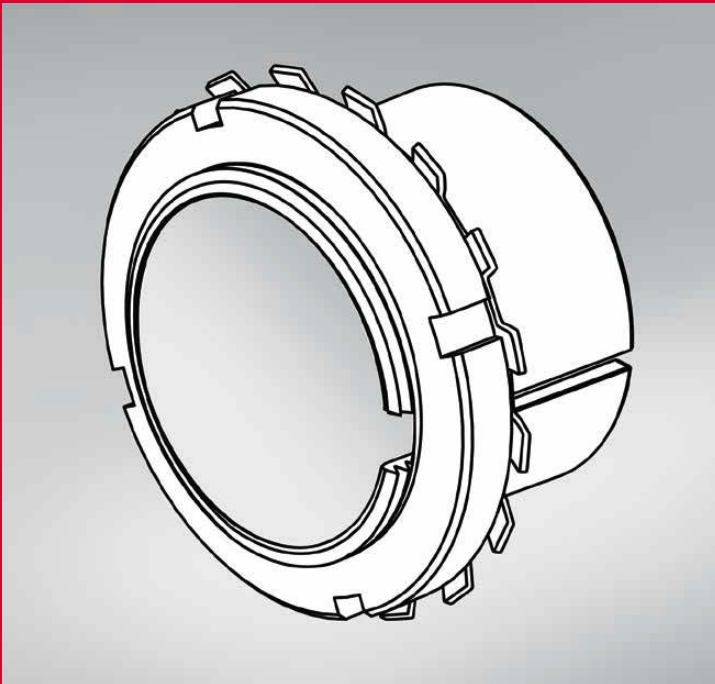

Accessories

Accessories which are used in the two ranges of plummer blocks are listed in this section. For other sizes or types, please refer to our catalogue E 1102.

Adapter Sleeves

Material: mild steel

Nuts: mild steel

Washers: mild steel

Locating Rings: aluminium

Plummer Blocks SNN and SD 3100 Series

Adapter Sleeves

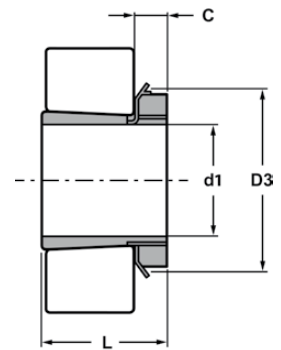

Adapter Sleeve	d1				L	D3	C	Weight	Lock Nut		Washer	
	H	HE	HS	HA					NSK	RHP	NSK	RHP
	mm	Inch	Inch	Inch					mm	mm	mm	kg
H205	20	3/4	7/8		26	38	8	0.070	AN05	KM05	AW05X	MB05
H206	25	1	7/8		27	45	8	0.099	AN06	KM06	AW06X	MB06
H207	30		1.1/8	1.3/16	29	52	9	0.125	AN07	KM07	AW07X	MB07
H208	35	1.3/4	1.3/8	1.5/16	31	58	10	0.174	AN08	KM08	AW08X	MB08
H209	40	1.1/2	1.5/8	1.7/16	33	65	11	0.227	AN09	KM09	AW09X	MB09
H210	45	1.3/4	1.5/8	1.11/16	35	70	12	0.274	AN10	KM10	AW10X	MB10
H211	50	2	1.7/8	1.15/16	37	75	12	0.308	AN11	KM11	AW11X	MB11
H212	55		2.1/8		38	80	13	0.346	AN12	KM12	AW12X	MB12
H213	60	2.1/4	2.3/8	2.3/16	40	85	14	0.401	AN13	KM13	AW13X	MB13
H215	65	2.1/2		2.7/16	43	98	15	0.707	AN15	KM15	AW15X	MB15
H216	70	2.3/4		2.11/16	46	105	17	0.882	AN16	KM16	AW16X	MB16
H217	75	3		2.15/16	50	110	18	1.020	AN17	KM17	AW17X	MB17
H218	80			3.3/16	52	120	18	1.190	AN18	KM18	AW18X	MB18
H219	85	3.1/4			55	125	19	1.370	AN19	KM19	AW19X	MB19
H220	90	3.1/2		3.7/16	58	130	20	1.490	AN20	KM20	AW20X	MB20
H222	100	4		3.15/16	63	145	21	1.930	AN22	KM22	AW22X	MB22
H305	20	3/4	7/8		29	38	8	0.075	AN05	KM05	AW05X	MB05
H306	25	1	7/8		31	45	8	0.109	AN06	KM06	AW06X	MB06
H307	30		1.1/8	1.3/16	35	52	9	0.142	AN07	KM07	AW07X	MB07
H308	35	1.3/4	1.3/8	1.5/16	36	58	10	0.189	AN08	KM08	AW08X	MB08
H309	40	1.1/2	1.5/8	1.7/16	39	65	11	0.248	AN09	KM09	AW09X	MB09
H310	45	1.3/4	1.5/8	1.11/16	42	70	12	0.303	AN10	KM10	AW10X	MB10
H311	50	2	1.7/8	1.15/16	45	75	12	0.345	AN11	KM11	AW11X	MB11
H312	55		2.1/8		47	80	13	0.394	AN12	KM12	AW12X	MB12
H313	60	2.1/4	2.3/8	2.3/16	50	85	14	0.458	AN13	KM13	AW13X	MB13
H315	65	2.1/2		2.7/16	55	98	15	0.831	AN15	KM15	AW15X	MB15
H316	70	2.3/4		2.11/16	59	105	17	1.030	AN16	KM16	AW16X	MB16
H317	75	3		2.15/16	63	110	18	1.180	AN17	KM17	AW17X	MB17
H318	80			3.3/16	65	120	18	1.370	AN18	KM18	AW18X	MB18
H319	85	3.1/4			68	125	19	1.560	AN19	KM19	AW19X	MB19
H320	90	3.1/2		3.7/16	71	130	20	1.690	AN20	KM20	AW20X	MB20
H322	100	4		3.15/16	77	145	21	2.180	AN22	KM22	AW22X	MB22

Plummer Blocks SNN and SD 3100 Series

Adapter Sleeves

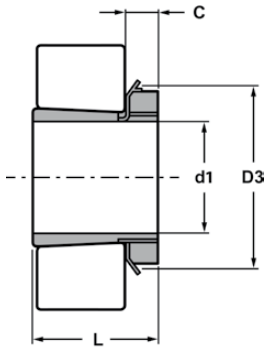

Adapter Sleeve	d1				L	D3	C	Weight	Lock Nut		Washer	
	H	HE	HS	HA					NSK	RHP	NSK	RHP
	mm	Inch	Inch	Inch					mm	mm	mm	kg
H2305	20	3/4			35	38	8	0.087	AN05	KM05	AW05X	MB05
H2306	25	1			38	45	8	0.126	AN06	KM06	AW06X	MB06
H2307	30				43	52	9	0.165	AN07	KM07	AW07X	MB07
H2308	35	1.1/4	1.3/8		46	58	10	0.224	AN08	KM08	AW08X	MB08
H2309	40	1.1/2		1.7/16	50	65	11	0.280	AN09	KM09	AW09X	MB09
H2310	45	1.3/4	1.5/8	1.11/16	55	70	12	0.362	AN10	KM10	AW10X	MB10
H2311	50	2	1.7/8	1.15/16	59	75	12	0.420	AN11	KM11	AW11X	MB11
H2312	55		2.1/8		62	80	13	0.481	AN12	KM12	AW12X	MB12
H2313	60	2.1/4	2.3/8	2.3/16	65	85	14	0.557	AN13	KM13	AW13X	MB13
H2315	65	2.1/2		2.7/16	73	98	15	1.050	AN15	KM15	AW15X	MB15
H2316	70	2.3/4		2.11/16	78	105	17	1.280	AN16	KM16	AW16X	MB16
H2317	75	3		2.15/16	82	110	18	1.450	AN17	KM17	AW17X	MB17
H2318	80			3.3/16	86	120	18	1.690	AN18	KM18	AW18X	MB18
H2319	85	3.1/4			90	125	19	1.920	AN19	KM19	AW19X	MB19
H2320	90	3.1/2		3.7/16	97	130	20	2.150	AN20	KM20	AW20X	MB20
H2322	100	4		3.15/16	105	145	21	2.740	AN22	KM22	AW22X	MB22
H2326	115	4.1/2		4.7/16	121	165	23	4.600	AN26	KM26	AW26X	MB26
H2328	125	5		4.15/16	131	180	24	5.550	AN28	KM28	AW28X	MB28
H2330	135	5.1/4		5.3/16	139	195	26	6.630	AN30	KM30	AW30X	MB30
H2332	140	5.1/2		5.7/16	147	210	28	9.140	AN32	KM32	AW32X	MB32
H3134	150	6		5.15/16	122	220	29	8.380	AN34	KM34	AW34X	MB34
H3136	160	6.1/2		6.7/16	131	230	30	9.500	AN36	KM36	AW36X	MB36
H3138	170	6.3/4		6.15/16	141	240	31	10.800	AN38	KM38	AW38X	MB38
H3140	180	7		7.3/16	150	250	32	12.100	AN40	KM40	AW40X	MB40
H3144	200			7.15/16	161	280	35	14.700	AN44	HM44T	AL44	MB44
H3148	220				172	300	37	17.300	AN48	HM48T	AL48	MB48
H3152	240				190	330	39	22.000	AN52	HMS2T	AL52	MB52
H3156	260				195	350	41	24.500	AN56	HMS6T	AL56	MB56
H3160	280				208	380	40	30.200	AN60	HM3160	AL60	MS3160
H3164	300				226	400	42	34.900	AN64	HM3164	AL64	MS3164
H3168	320				254	440	55	49.500	AN68	HM3168	AL68	MS3168
H3172	340				259	460	58	54.200	AN72	HM3172	AL72	MS3172
H3176	360				264	490	60	61.700	AN76	HM3176	AL76	MS3176
H3180	380				272	520	62	70.600	AN80	HM3180	AL80	MS3180

Plummer Blocks SNN and SD 3100 Series

Lock Nuts

Nut with Washer from AN05/KM05 to AN40/KM40

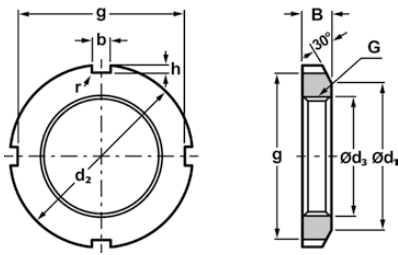

Nut with Stopper from AN44/HM44T

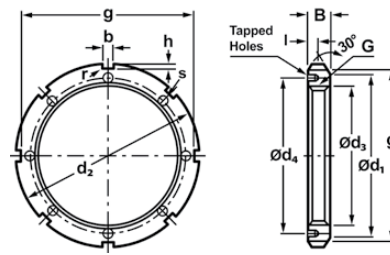

Lock Nuts		d ₂ mm	d ₁ mm	g mm	d ₃ mm	Thread G	B mm	b mm	h mm	l	Tapped Holes Screw Threads	D5	Weight kg	Washer	
NSK	RHP													NSK	RHP
Part Number	Part Number													Part Number	Part Number
AN05	KM05	38	32	34	25.8	M25x1.5	7	5	2.0				0.025	AW05X	MB05
AN06	KM06	45	38	41	30.8	M30x1.5	7	5	2.0				0.043	AW06X	MB06
AN07	KM07	52	44	48	35.8	M35x1.5	8	5	2.0				0.053	AW07X	MB07
AN08	KM08	58	50	53	40.8	M40x1.5	9	6	2.5				0.085	AW08X	MB08
AN09	KM09	65	56	60	45.8	M45x1.5	10	6	2.5				0.119	AW09X	MB09
AN10	KM10	70	61	65	50.8	M50x1.5	11	6	2.5				0.148	AW10X	MB10
AN11	KM11	75	67	69	56.0	M55x2	11	7	3.0				0.158	AW11X	MB11
AN12	KM12	80	73	74	61.0	M60x2	11	7	3.0				0.174	AW12X	MB12
AN13	KM13	85	79	79	66.0	M65x2	12	7	3.0				0.203	AW13X	MB13
AN15	KM15	98	90	91	76.0	M75x2	13	8	3.5				0.287	AW15X	MB15
AN16	KM16	105	95	98	81.0	M80x2	15	8	3.5				0.397	AW16X	MB16
AN17	KM17	110	102	103	86.0	M85x2	16	8	3.5				0.451	AW17X	MB17
AN18	KM18	120	108	112	91.0	M90x2	16	10	4.0				0.556	AW18X	MB18
AN19	KM19	125	113	117	96.0	M95x2	17	10	4.0				0.658	AW19X	MB19
AN20	KM20	130	120	122	101.0	M100x2	18	10	4.0				0.698	AW20X	MB20
AN22	KM22	145	133	135	111.0	M110x2	19	12	5.0				0.965	AW22X	MB22
AN24	KM24	155	138	145	121.0	M120x2	20	12	5.0				1.080	AW24X	MB24
AN26	KM26	165	149	155	131.0	M130x2	21	12	5.0				1.250	AW26X	MB26
AN28	KM28	180	160	168	141.0	M140x2	22	14	6.0				1.560	AW28X	MB28
AN30	KM30	195	171	183	151.0	M150x2	24	14	6.0				2.030	AW30X	MB30
AN32	KM32	210	182	196	161.5	M160x3	25	16	7.0				2.590	AW32X	MB32
AN34	KM34	220	193	206	171.5	M170x3	26	16	7.0				2.800	AW34X	MB34
AN36	KM36	230	203	214	181.5	M180x3	27	18	8.0				3.070	AW36X	MB36
AN38	KM38	240	214	224	191.5	M190x3	28	18	8.0				3.390	AW38X	MB38
AN40	KM40	250	226	234	201.5	M200x3	29	18	8.0				3.690	AW40X	MB40
AN44	HM44T	280	250	260	222.0	M220x4	32	20	10.0	15	M8x1.25	238	5.200	AL44	MB44
AN48	HM48T	300	270	280	242.0	M240x4	34	20	10.0	15	M8x1.25	258	5.950	AL48	MB48
AN52	HM52T	330	300	306	262.0	M260x4	36	24	12.0	18	M10x1.5	281	8.050	AL52	MB52
AN56	HM56T	350	320	326	282.0	M280x4	38	24	12.0	18	M10x1.5	301	9.050	AL56	MB56
AN60	HM3160	380	340	356	302.0	M300x4	40	24	12.0	18	M10x1.5	326	11.800	AL60	MS3160
AN64	HM3164	400	360	376	322.5	M320x5	42	24	12.0	18	M10x1.5	345	13.100	AL64	MS3164
AN68	HM3168	440	400	410	342.5	M340x5	55	28	15.0	21	M12x1.75	372	23.100	AL68	MS3168
AN72	HM3172	460	420	430	362.5	M360x5	58	28	15.0	21	M12x1.75	392	25.100	AL72	MS3172
AN76	HM3176	490	450	454	382.5	M380x5	60	32	18.0	21	M12x1.75	414	31.000	AL76	MS3176
AN80	HM3180	520	470	484	402.5	M400x5	62	32	18.0	27	M16x2	439	37.000	AL80	MS3180

Plummer Blocks SNN and SD 3100 Series

Washer

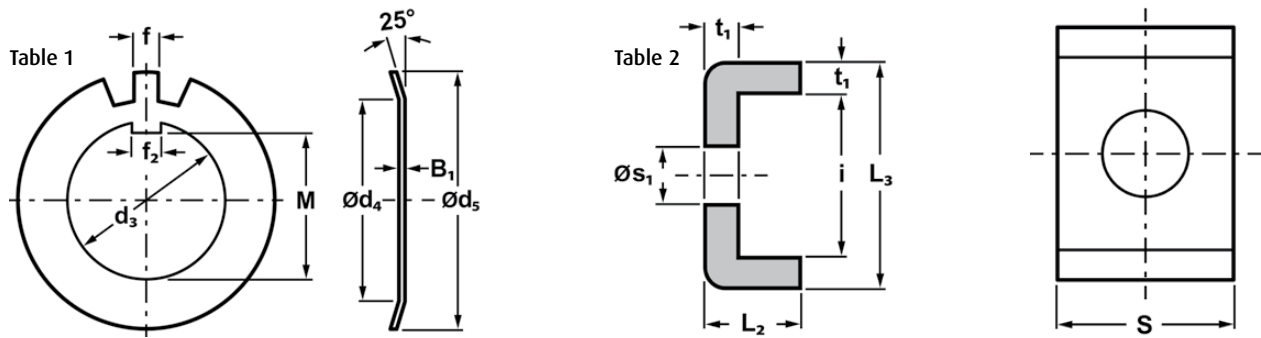

Table 1

Washer		d ₃	M	f ₁	B ₁	f	d ₄	d ₅	Number of Teeth	Mass kg (100 Pcs) approx.	Lock Nuts	
NSK	RHP										NSK	RHP
Part Number	Part Number	mm	mm	mm	mm	mm	mm	mm			Part Number	Part Number
AW05X	MB05	25	23.0	5	1.2	5	32	42	13	0.64	AN05	KM05
AW06X	MB06	30	27.5	5	1.2	5	38	49	13	0.78	AN06	KM06
AW07X	MB07	35	32.5	6	1.2	5	44	57	15	1.04	AN07	KM07
AW08X	MB08	40	37.5	6	1.2	6	50	62	15	1.23	AN08	KM08
AW09X	MB09	45	42.5	6	1.2	6	56	69	17	1.52	AN09	KM09
AW10X	MB10	50	47.5	6	1.2	6	61	74	17	1.60	AN10	KM10
AW11X	MB11	55	52.5	8	1.2	7	67	81	17	1.96	AN11	KM11
AW12X	MB12	60	57.5	8	1.5	7	73	86	17	2.53	AN12	KM12
AW13X	MB13	65	62.5	8	1.5	7	79	92	19	2.90	AN13	KM13
AW15X	MB15	75	71.5	8	1.5	8	90	104	19	3.55	AN15	KM15
AW16X	MB16	80	76.5	10	1.8	8	95	112	19	4.65	AN16	KM16
AW17X	MB17	85	81.5	10	1.8	8	102	119	19	5.25	AN17	KM17
AW18X	MB18	90	86.5	10	1.8	10	108	126	19	6.25	AN18	KM18
AW19X	MB19	95	91.5	10	1.8	10	113	133	19	6.70	AN19	KM19
AW20X	MB20	100	96.5	12	1.8	10	120	142	19	7.65	AN20	KM20
AW22X	MB22	110	105.5	12	1.8	12	133	154	19	9.40	AN22	KM22
AW24X	MB24	120	115.0	14	2.0	12	138	164	19	10.50	AN24	KM24
AW26X	MB26	130	125.0	14	2.0	12	149	175	19	11.30	AN26	KM26
AW28X	MB28	140	135.0	16	2.0	14	160	192	19	14.20	AN28	KM28
AW30X	MB30	150	145.0	16	2.0	14	171	205	19	15.90	AN30	KM30
AW32X	MB32	160	154.0	18	2.5	16	182	217	19	22.20	AN32	KM32
AW34X	MB34	170	164.0	18	2.5	16	193	232	19	24.70	AN34	KM34
AW36X	MB36	180	174.0	20	2.5	18	203	242	19	26.80	AN36	KM36
AW38X	MB38	190	184.0	20	2.5	18	214	252	19	27.80	AN38	KM38
AW40X	MB40	200	194.0	20	2.5	18	226	262	19	29.30	AN40	KM40

Table 2

Washer		t ₁	S	L ₂	S ₁	i	L ₃	Mass kg (100 Pcs) approx.	Lock Nuts		
NSK	RHP								NSK	RHP	
Part Number	Part Number	mm	mm	mm	mm	mm	mm			Part Number	Part Number
AL44	MB44	4	20	12	9	22.5	30.5	2.60		AN44	HM44T
AL48	MB48	4	20	12	9	22.5	30.5	2.60		AN48	HM48T
AL52	MB52	4	24	12	12	25.5	33.5	3.40		AN52	HM52T
AL56	MB56	4	24	12	12	25.5	33.5	3.40		AN56	HM56T
AL60	MS3160	4	24	12	12	30.5	38.5	3.80		AN60	HM3160
AL64	MS3164	5	24	15	12	31.0	41.0	5.35		AN64	HM3164
AL68	MS3168	5	28	15	14	38.0	48.0	6.65		AN68	HM3168
AL72	MS3172	5	28	15	14	38.0	48.0	6.65		AN72	HM3172
AL76	MS3176	5	32	15	14	40.0	50.0	7.95		AN76	HM3176
AL80	MS3180	5	32	15	18	45.0	55.0	8.20		AN80	HM3180

Interchange Lists

The purpose of the following lists is to make it easy for bearing users to identify the NSK parts that correspond to various non NSK plummer blocks and accessories which have been removed from equipment and need replacing.

The list identifies the different components using part numbering systems. Users should then consult the relevant table to check the dimensions and select the precise designation. The NSK product is a functional equivalent in respect of the key features, although secondary dimensions may differ.

If you cannot find a part number in the list or if you are unsure about anything, please contact your local NSK office to ensure you get the right NSK part number.

This list is provided in good faith, but no responsibility can be accepted for errors or omissions.

The manufacturers included are:

- › SKF
- › SNR
- › FAG
- › RHP

Interchange Lists

Plummer Block Housings for Tapered Bore Bearings

SKF / SNL	FAG / SNV	SNR / SNC	RHP / SNU	NSK / SNN
SNL505V	SNV052-L	SNC505	SNU505	SNN505
SNL506-605V	SNV062-L	SNC506-605	SNU506-605	SNN506-605
SNL507-606V	SNV072-L	SNC507-606	SNU507-606	SNN507-606
SNL508-607V	SNV080-L	SNC508-607	SNU508-607	SNN508-607
SNL509V	SNV085-L	SNC509	SNU509	SNN509
SNL510-608V	SNV090-L	SNC510-608	SNU510-608	SNN510-608
SNL511-609V	SNV100-L	SNC511-609	SNU511-609	SNN511-609
SNL512-610V	SNV110-L	SNC512-610	SNU512-610	SNN512-610
SNL513-611V	SNV120-L	SNC513-611	SNU513-611	SNN513-611
SNL515-612V	SNV130-L	SNC515-612	SNU515-612	SNN515-612
SNL516-613V	SNV140-L	SNC516-613	SNU516-613	SNN516-613
SNL517V	SNV150-L	SNC517	SNU517	SNN517
SNL518-615V	SNV160-L	SNC518-615	SNU518-615	SNN518-615
SNL519-616V	SNV170-L	SNC519-616	SNU519-616	SNN519-616
SNL520-617V	SNV180-L	SNC520-617	SNU520-617	SNN520-617
SNL522-619V	SNV200-L	SNC522-619	SNU522-619	SNN522-619
SNL524-620V	SNV215-L	SNC524-620	SNU524-620	SNN524-620
SNL526V	SNV230-L	SNC526	SNU526	SNN526
SNL528V	SNV250-L	SNC528	SNU528	SNN528
SNL530V	SNV270-L	SNC530	SNU530	SNN530
SNL532V	SNV290-L	SNC532	SNU532	SNN532
SNL3134	SD3134	-	SD3134	-
SNL3136	SD3136	-	SD3136	-
SNL3138	SD3138	-	SD3138	-
SNL3140	SD3140	-	SD3140	-
SNL3144	SD3144	-	SD3144	-
SNL3148	SD3148	-	SD3148	-
SNL3152	SD3152	-	SD3152	-
SNL3156	SD3156	-	SD3156	-
SNL3160	SD3160	-	SD3160	-
SNL3164	SD3164	-	SD3164	-
SNL3168	SD3168	-	SD3168	-
SNL3172	SD3172	-	SD3172	-
SNL3176	SD3176	-	SD3176	-
SNL3180	SD3180	-	SD3180	-

Felt Seals for Plummer Blocks 500–600 Series

SKF / SNL	FAG / SNV	SNR / SNC	RHP / SNU	NSK / SNN
TSN505C	FSV505	SC505FS	-	C505-KIT
TSN506C	FSV506	SC506FS	-	C506-KIT
TSN507C	FSV507	SC507FS	-	C507-KIT
TSN508C	FSV508	SC508FS	-	C508-KIT
TSN509C	FSV509	SC509FS	-	C509-KIT
TSN510C	FSV510	SC510FS	-	C510-KIT
TSN511C	FSV511	SC511FS	-	C511-KIT
TSN512C	FSV512	SC512FS	-	C512-KIT
TSN513C	FSV513	SC513FS	-	C513-KIT
TSN515C	FSV515	SC515FS	-	C515-KIT
TSN516C	FSV516	SC516FS	-	C516-KIT
TSN517C	FSV517	SC517FS	-	C517-KIT
TSN518C	FSV518	SC518FS	-	C518-KIT
TSN519C	FSV519	SC519FS	-	C519-KIT
TSN520C	FSV520	SC520FS	-	C520-KIT
TSN522C	FSV522	SC522FS	-	C522-KIT
TSN524C	FSV524	SC524FS	-	C524-KIT
TSN526C	FSV526	SC526FS	-	C526-KIT
TSN528C	FSV528	SC528FS	-	C528-KIT
TSN530C	FSV530	SC530FS	-	C530-KIT
TSN532C	FSV532	SC532FS	-	C532-KIT
TSN605C	FSV605	SC605FS	-	C605-KIT
TSN606C	FSV606	SC606FS	-	C606-KIT
TSN607C	FSV607	SC607FS	-	C607-KIT
TSN608C	FSV608	SC608FS	-	C608-KIT
TSN609C	FSV609	SC609FS	-	C609-KIT
TSN610C	FSV610	SC610FS	-	C610-KIT
TSN611C	FSV611	SC611FS	-	C611-KIT
TSN612C	FSV612	SC612FS	-	C612-KIT
TSN613C	FSV613	SC613FS	-	C613-KIT
TSN615C	FSV615	SC615FS	-	C615-KIT
TSN616C	FSV616	SC616FS	-	C616-KIT
TSN617C	FSV617	SC617FS	-	C617-KIT
TSN619C	FSV619	SC619FS	-	C619-KIT
TSN620C	FSV620	SC620FS	-	C620-KIT

Interchange Lists

Double Lip Seals for Plummer Blocks 500–600 Series

SKF / SNL	FAG / SNV	SNR / SNC	RHP / SNU	NSK / SNN
TSN505G	DH505	SC505DS	U505	G505-KIT
TSN506G	DH506	SC506DS	U506	G506-KIT
TSN507G	DH507	SC507DS	U507	G507-KIT
TSN508G	DH508	SC508DS	U508	G508-KIT
TSN509G	DH509	SC509DS	U509	G509-KIT
TSN510G	DH510	SC510DS	U510	G510-KIT
TSN511G	DH511	SC511DS	U511	G511-KIT
TSN512G	DH512	SC512DS	U512	G512-KIT
TSN513G	DH513	SC513DS	U513	G513-KIT
TSN515G	DH515	SC515DS	U515	G515-KIT
TSN516G	DH516	SC516DS	U516	G516-KIT
TSN517G	DH517	SC517DS	U517	G517-KIT
TSN518G	DH518	SC518DS	U518	G518-KIT
TSN519G	DH519	SC519DS	U519	G519-KIT
TSN520G	DH520	SC520DS	U520	G520-KIT
TSN522G	DH522	SC522DS	U522	G522-KIT
TSN524G	DH524	SC524DS	U524	G524-KIT
TSN526G	DH526	SC526DS	U526	G526-KIT
TSN528G	DH528	SC528DS	U528	G528-KIT
TSN530G	DH530	SC530DS	U530	G530-KIT
TSN532G	DH532	SC532DS	U532	G532-KIT
TSN605G	DH605	SC605DS	U605	G605-KIT
TSN606G	DH606	SC606DS	U606	G606-KIT
TSN607G	DH607	SC607DS	U607	G607-KIT
TSN608G	DH608	SC608DS	U608	G608-KIT
TSN609G	DH609	SC609DS	U609	G609-KIT
TSN610G	DH610	SC610DS	U610	G610-KIT
TSN611G	DH611	SC611DS	U611	G611-KIT
TSN612G	DH612	SC612DS	U612	G612-KIT
TSN613G	DH613	SC613DS	U613	G613-KIT
TSN615G	DH615	SC615DS	U615	G615-KIT
TSN616G	DH616	SC616DS	U616	G616-KIT
TSN617G	DH617	SC617DS	U617	G617-KIT
TSN619G	DH619	SC619DS	U619	G619-KIT
TSN620G	DH620	SC620DS	U620	G620-KIT

V-Ring Seals for Plummer Blocks 500–600 Series

SKF / SNL	FAG / SNV	SNR / SNC	RHP / SNU	NSK / SNN
TSN505A	DHV505	SC505SV	TSNA505	V505-KIT
TSN506A	DHV506	SC506SV	TSNA506	V506-KIT
TSN507A	DHV507	SC507SV	TSNA507	V507-KIT
TSN508A	DHV508	SC508SV	TSNA508	V508-KIT
TSN509A	DHV509	SC509SV	TSNA509	V509-KIT
TSN510A	DHV510	SC510SV	TSNA510	V510-KIT
TSN511A	DHV511	SC511SV	TSNA511	V511-KIT
TSN512A	DHV512	SC512SV	TSNA512	V512-KIT
TSN513A	DHV513	SC513SV	TSNA513	V513-KIT
TSN515A	DHV515	SC515SV	TSNA515	V515-KIT
TSN516A	DHV516	SC516SV	TSNA516	V516-KIT
TSN517A	DHV517	SC517SV	TSNA517	V517-KIT
TSN518A	DHV518	SC518SV	TSNA518	V518-KIT
TSN519A	DHV519	SC519SV	TSNA519	V519-KIT
TSN520A	DHV520	SC520SV	TSNA520	V520-KIT
TSN522A	DHV522	SC522SV	TSNA522	V522-KIT
TSN524A	DHV524	SC524SV	TSNA524	V524-KIT
TSN526A	DHV526	SC526SV	TSNA526	V526-KIT
TSN528A	DHV528	SC528SV	TSNA528	V528-KIT
TSN530A	DHV530	SC530SV	TSNA530	V530-KIT
TSN532A	DHV532	SC532SV	TSNA532	V532-KIT
TSN605A	DHV605	SC605SV	TSNA605	V605-KIT
TSN606A	DHV606	SC606SV	TSNA606	V606-KIT
TSN607A	DHV607	SC607SV	TSNA607	V607-KIT
TSN608A	DHV608	SC608SV	TSNA608	V608-KIT
TSN609A	DHV609	SC609SV	TSNA609	V609-KIT
TSN610A	DHV610	SC610SV	TSNA610	V610-KIT
TSN611A	DHV611	SC611SV	TSNA611	V611-KIT
TSN612A	DHV612	SC612SV	TSNA612	V612-KIT
TSN613A	DHV613	SC613SV	TSNA613	V613-KIT
TSN615A	DHV615	SC615SV	TSNA615	V615-KIT
TSN616A	DHV616	SC616SV	TSNA616	V616-KIT
TSN617A	DHV617	SC617SV	TSNA617	V617-KIT
TSN619A	DHV619	SC619SV	TSNA619	V619-KIT
TSN620A	DHV620	SC620SV	TSNA620	V620-KIT

Interchange Lists

Labyrinth Seals for Plummer Blocks 500–600 Series

SKF / SNL	FAG / SNV	SNR / SNC	RHP / SNU	NSK / SNN
TSN505S	TSV505	SC505LA	TS505U	TS505U
TSN506S	TSV506	SC506LA	TS506U	TS506U
TSN507S	TSV507	SC507LA	TS507U	TS507U
TSN508S	TSV508	SC508LA	TS508U	TS508U
TSN509S	TSV509	SC509LA	TS509U	TS509U
TSN510S	TSV510	SC510LA	TS510U	TS510U
TSN511S	TSV511	SC511LA	TS511U	TS511U
TSN512S	TSV512	SC512LA	TS512U	TS512U
TSN513S	TSV513	SC513LA	TS513U	TS513U
TSN515S	TSV515	SC515LA	TS515U	TS515U
TSN516S	TSV516	SC516LA	TS516U	TS516U
TSN517S	TSV517	SC517LA	TS517U	TS517U
TSN518S	TSV518	SC518LA	TS518U	TS518U
TSN519S	TSV519	SC519LA	TS519U	TS519U
TSN520S	TSV520	SC520LA	TS520U	TS520U
TSN522S	TSV522	SC522LA	TS522U	TS522U
TSN524S	TSV524	SC524LA	TS524U	TS524U
TSN526S	TSV526	SC526LA	TS526U	TS526U
TSN528S	TSV528	SC528LA	TS528U	TS528U
TSN530S	TSV530	SC530LA	TS530U	TS530U
TSN532S	TSV532	SC532LA	TS532U	TS532U
TSN605S	TSV605	SC605LA	TS605U	TS605U
TSN606S	TSV606	SC606LA	TS606U	TS606U
TSN607S	TSV607	SC607LA	TS607U	TS607U
TSN608S	TSV608	SC608LA	TS608U	TS608U
TSN609S	TSV609	SC609LA	TS609U	TS609U
TSN610S	TSV610	SC610LA	TS610U	TS610U
TSN611S	TSV611	SC611LA	TS611U	TS611U
TSN612S	TSV612	SC612LA	TS612U	TS612U
TSN613S	TSV613	SC613LA	TS613U	TS613U
TSN615S	TSV615	SC615LA	TS615U	TS615U
TSN616S	TSV616	SC616LA	TS616U	TS616U
TSN617S	TSV617	SC617LA	TS617U	TS617U
TSN619S	TSV619	SC619LA	TS619U	TS619U
TSN620S	TSV620	SC620LA	TS620U	TS620U

Taconite Seals for Plummer Blocks 500–600 Series

SKF / SNL	FAG / SNV	SNR / SNC	RHP / SNU	NSK / SNN
TSN505ND	-	SC505TA	-	TACK505
TSN506ND	-	SC506TA	-	TACK506
TSN507ND	-	SC507TA	-	TACK507
TSN508ND	TCV508	SC508TA	-	TACK508
TSN509ND	TCV509	SC509TA	-	TACK509
TSN510ND	TCV510	SC510TA	-	TACK510
TSN511ND	TCV511	SC511TA	-	TACK511
TSN512ND	TCV512	SC512TA	-	TACK512
TSN513ND	TCV513	SC513TA	-	TACK513
TSN515ND	TCV515	SC515TA	-	TACK515
TSN516ND	TCV516	SC516TA	-	TACK516
TSN517ND	TCV517	SC517TA	-	TACK517
TSN518ND	TCV518	SC518TA	-	TACK518
TSN519ND	TCV519	SC519TA	-	TACK519
TSN520ND	TCV520	SC520TA	-	TACK520
TSN522ND	TCV522	SC522TA	-	TACK522
TAN524ND	TCV524	SC524TA	-	TACK524
TSN526ND	TCV526	SC526TA	-	TACK526
TSN528ND	TCV528	SC528TA	-	TACK528
TSN530ND	TCV530	SC530TA	-	TACK530
TSN532ND	TCV532	SC532TA	-	TACK532
TSN605ND	-	SC605TA	-	TACK605
TSN606ND	TCV606	SC606TA	-	TACK606
TSN607ND	TCV607	SC607TA	-	TACK607
TSN608ND	TCV608	SC608TA	-	TACK608
TSN609ND	TCV609	SC609TA	-	TACK609
TSN610ND	TCV610	SC610TA	-	TACK610
TSN611ND	TCV611	SC611TA	-	TACK611
TSN612ND	TCV612	SC612TA	-	TACK612
TSN613ND	TCV613	SC613TA	-	TACK613
TSN615ND	TCV615	SC615TA	-	TACK615
TSN616ND	TCV616	SC616TA	-	TACK616
TSN617ND	TCV617	SC617TA	-	TACK617
TSN619ND	TCV619	SC619TA	-	TACK619
TSN620ND	-	SC620TA	-	TACK620

Interchange Lists

End Covers for Plummer Blocks 500–600 Series

SKF / SNL	FAG / SNV	SNR / SNC	RHP / SNU	NSK / SNN
ASNH505	DKV052	SC505EC	505A	505A
ASNH506-605	DKV062	SC506-605EC	506A	506A
ASNH507-606	DKV072	SC507-606EC	507A	507A
ASNH508-607	DKV080	SC508-607EC	508A	508A
ASNH509	DKV085	SC509EC	509A	509A
ASNH510-608	DKV090	SC510-608EC	510A	510A
ASNH511-609	DKV100	SC511-609EC	511A	511A
ASNH512-610	DKV110	SC512-610EC	512A	512A
ASNH513-611	DKV120	SC513-611EC	513A	513A
ASNH515-612	DKV130	SC515-612EC	515A	515A
ASNH516-613	DKV140	SC516-613EC	516A	516A
ASNH517	DKV150	SC517EC	517A	517A
ASNH518-615	DKV160	SC518-615EC	518A	518A
ASNH519-616	DKV170	SC519-616EC	519A	519A
ASNH520-617	DKV180	SC520-617EC	520A	520A
ASNH522-619	DKV200	SC522-619EC	522A	522A
ASNH524-620	DKV215	SC524-620EC	524A	524A
ASNH526	DKV230	SC526EC	526A	526A
ASNH528	DKV250	SC528EC	528A	528A
ASNH530	DKV270	SC530EC	530A	530A
ASNH532	DKV290	SC532EC	532A	532A

Labyrinth Seals for Plummer Blocks SD 3100 Series

SKF / SD	FAG / SD	SNR / -	RHP / SD	NSK / -
TS34	TS34	-	TS34	-
TS36	TS36	-	TS36	-
TS38	TS38	-	TS38	-
TS40	TS40	-	TS40	-
TS44	TS44	-	TS44	-
TS48	TS48	-	TS48	-
TS52	TS52	-	TS52	-
TS56	TS56	-	TS56	-
TS60	TS60	-	TS60	-
TS64	TS64	-	TS64	-
TS68	TS68	-	TS68	-
TS72	TS72	-	TS72	-
TS76	TS76	-	TS76	-
TS80	TS80	-	TS80	-

End Covers for Plummer Blocks SD 3100 Series

SKF / SD	FAG / SD	SNR / -	RHP / SD	NSK / -
ETS34	Included in Housing Part Number (Suffix AF or AL)	-	TSA34	-
ETS36		-	TSA36	-
ETS38		-	TSA38	-
ETS40		-	TSA40	-
ETS44		-	TSA44	-
ETS48		-	TSA48	-
ETS52		-	TSA52	-
ETS56		-	TSA56	-
ETS60		-	TSA60	-
ETS64		-	TSA64	-
ETS68		-	TSA68	-
ETS72		-	TSA72	-
ETS76		-	TSA76	-
ETS80		-	TSA80	-

Taconite Seals for Plummer Blocks SD 3100 Series

SKF / SD	FAG / SD	SNR / -	RHP / SD	NSK / -
TNF34	-	-	TACSD34	-
TNF36	-	-	TACSD36	-
TNF38	-	-	TACSD38	-
TNF40	-	-	TACSD40	-
TNF44	-	-	TACSD44	-
TNF48	-	-	TACSD48	-
TNF52	-	-	TACSD52	-
TNF56	-	-	TACSD56	-
TNF60	-	-	TACSD60	-
TNF64	-	-	TACSD64	-
TNF68	-	-	TACSD68	-
TNF72	-	-	TACSD72	-
TNF76	-	-	TACSD76	-
TNF80	-	-	TACSD80	-

Maintenance

Plummer blocks typical arrangement

Usually, a shaft is supported by 2 plummer blocks or more if the shaft is very long. One plummer block will locate the shaft axially. This bearing is referred to as the "Fixed End".

In the fixed plummer block, to prevent axial displacement of the bearing, 2 locating rings are installed, one on either side of the bearing. Axial displacement of the shaft is then impossible (**Fig. 1**). If the system is subjected to variations of temperature, the shaft may expand or contract axially.

If both bearings are fixed, this could result in excessive loading on the bearing set, resulting in reduced service life. For this reason, one bearing should be free to move axially. This bearing is referred to as the "Free End" or "Floating End". This plummer block should not be assembled with locating rings. The absence of locating rings combined with the H7 bearing seating tolerance will allow the bearing to move axially if required (**Fig. 2**).

Locating rings for each housing size and bearing type are detailed on page 18 and 22.

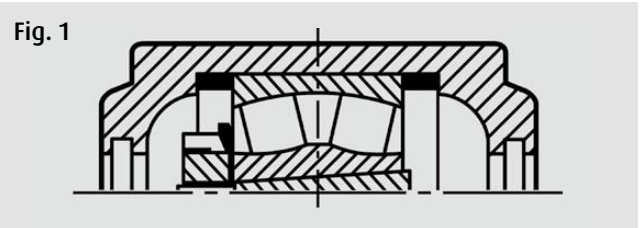

Fig.1: In the fixed plummer block, to prevent axial displacement of the bearing, 2 locating rings are installed, one on either side of the bearing. Locating rings are manufactured in aluminium.

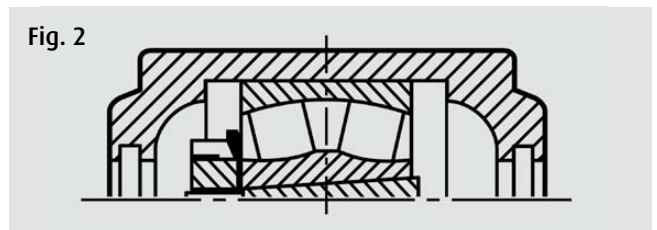

Fig.2: One bearing should be free to move axially. This plummer block should not be assembled with locating rings.

Lubrication

SNN plummer blocks have been developed primarily for grease lubrication.

NSK SNN housings are equipped as standard with 1 straight grease nipple, 2 lubrication holes, 1 on one side of the cap, the other in the centre of the cap to enable lubrication through the bearing outer ring grease groove. This relubrication method is preferred as fresh grease is delivered directly to the bearing. SNN housings are also equipped with a threaded drain hole.

The application conditions (speeds, loads, temperature) will determine the grease re-lubrication intervals and quantity. However, in addition to the bearing grease fill, it is necessary to fill the housing with a certain quantity of grease before the first use. For recommended grease weight/initial fill, please refer to the table on the right side.



SNN Housing	Grease Weight Initial Fill (g)
SNN505	25
SNN506-605	40
SNN507-606	50
SNN508-607	60
SNN509	65
SNN510-608	75
SNN511-609	100
SNN512-610	150
SNN513-611	180
SNN515-612	230
SNN516-613	280
SNN517	330
SNN518-615	430
SNN519-616	480
SNN520-617	630
SNN522-619	850
SNN524-620	1000
SNN526	1100
SNN528	1400
SNN530	1700
SNN532	2000

Housing	Size of Grease Nipple	Size of Threaded Drain Hole
SNN505 to SNN515-612	R1/8	R1/8
SNN516-613 to SNN522-619	R1/4	R1/4
SNN524-620 to SNN532	R3/8	R3/8

Mounting of Spherical Roller Bearings on Adapter Sleeves

1. With bearing on bench check clearance using the feeler gauges over the top of the rollers at the top of the bearing as shown in **Fig. 1** and note the clearance.
2. Before mounting, smear the thread and the side face of the nut with a molybdenum disulphide paste or similar lubricant.
3. Smear the shaft and outside diameter of sleeve with a light oil.
4. Open the sleeve slightly by inserting and twisting a screw driver into the slit in the sleeve and position the sleeve on the shaft.
5. Slide bearing, lockwasher and locknut onto sleeve and tighten nut with a 'C' spanner until all slackness is removed.
6. Further tighten the nut until the clearance has been reduced by the amount shown in the chart on page 24 but when the bearing is mounted on the shaft the clearance should be checked under the rollers at the bottom of the bearing as shown in **Fig. 2**.
7. Check the clearance has not been reduced below the minimum permissible residual clearance shown in the chart on page 24 for the size and clearance of bearing.
8. Align one tab on the lock washer with a slot in the locknut and bend it into the slot, if no tabs line up with the slots slightly tighten the locknut until one lines up. **Never back off the nut to line up the tab with the slot.**
9. Check the bearing rotates freely without any binding.

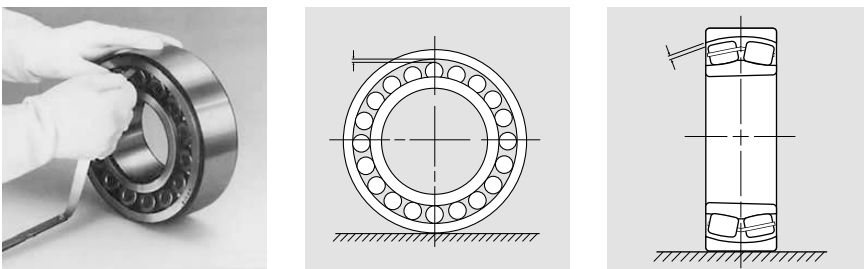

Fig. 1: Checking bearing clearance with bearing on bench.

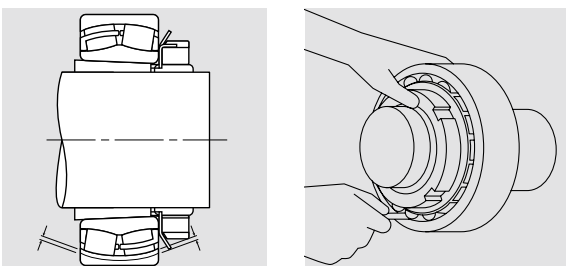

Fig. 2: Checking bearing clearance with bearing mounted on shaft.

Mounting of Spherical Roller Bearings on an Adapter Sleeve using the Axial Drive-Up Method

1. Before mounting, smear the thread and the side face of the nut with a molybdenum disulphide paste or similar lubricant.
2. Smear the shaft and outside diameter of sleeve with a light oil.
3. Open the sleeve slightly by inserting and twisting a screwdriver into the slit in the sleeve and position the sleeve on the shaft.
4. Slide bearing, lockwasher and locknut onto sleeve and tighten nut with a 'C' spanner until all slackness is removed.
5. Measure dimension 'X' as shown in **Fig. 3**.
6. Tighten the nut and **decrease** dimension 'X' by the amount of axial drive-up shown in the chart on page 24 for the correct size of bearing.
7. Check bearing clearance as shown on page 22 to ensure the clearance is not less than the minimum permissible residual clearance shown in the chart on page 24 for the size and clearance of bearing.
8. Align one tab on the lock washer with a slot in the locknut and bend it into the slot, if no tabs line up with the slots slightly tighten the locknut until one lines up. **Never back off the nut to line up the tab with the slot.**
9. Check the bearing rotates freely without binding.

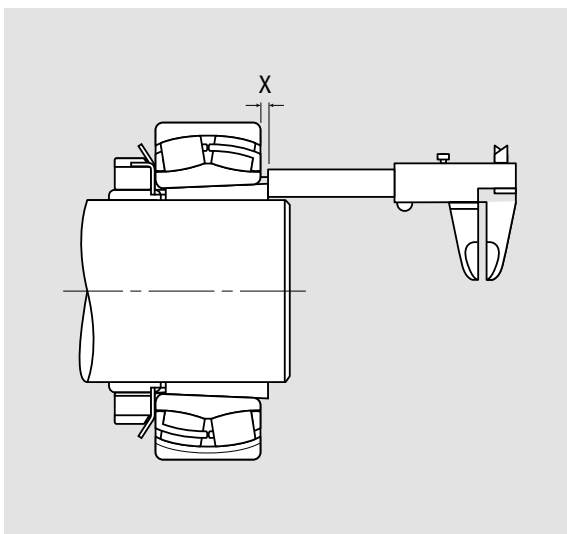

Fig. 3

Mounting of Spherical Roller Bearings

Radial Internal Clearance

Bearing Bore Diameter mm		Initial Radial Internal Clearance						Reduction in Radial Clearance		Axial Drive-Up		Nominal Tightening Angle	Minimum Permissible Residual Clearance		
over	incl.	CN		C3		C4		min	max	min	max	nominal	CN	C3	C4
		min	max	min	max	min	max								
30	40	0.035	0.050	0.050	0.065	0.065	0.085	0.25	0.030	0.40	0.45	100°	0.010	0.250	0.035
40	50	0.045	0.060	0.060	0.080	0.080	0.100	0.030	0.035	0.45	0.55	120°	0.015	0.030	0.045
50	65	0.055	0.075	0.075	0.095	0.095	0.120	0.030	0.035	0.45	0.55	90°	0.025	0.035	0.060
65	80	0.070	0.095	0.095	0.120	0.120	0.150	0.040	0.040	0.60	0.70	120°	0.030	0.040	0.075
80	100	0.080	0.110	0.110	0.140	0.140	0.180	0.045	0.055	0.070	0.85	140°	0.035	0.050	0.085
100	120	0.100	0.135	0.135	0.170	0.170	0.220	0.050	0.060	0.75	0.90		0.045	0.065	0.110
120	140	0.120	0.160	0.160	0.200	0.200	0.260	0.060	0.070	0.90	1.10		0.055	0.080	0.130
140	160	0.130	0.180	0.180	0.230	0.230	0.300	0.065	0.080	1.00	1.30		0.060	0.100	0.150
160	180	0.140	0.200	0.200	0.260	0.260	0.340	0.070	0.090	1.10	1.40		0.070	0.110	0.170
180	200	0.160	0.220	0.220	0.290	0.290	0.370	0.080	0.100	1.30	1.60		0.070	0.110	0.190
200	225	0.180	0.250	0.250	0.320	0.320	0.410	0.090	0.110	1.40	1.70		0.080	0.130	0.210
225	250	0.200	0.270	0.270	0.350	0.350	0.450	0.100	0.120	1.60	1.90		0.090	0.140	0.230
250	280	0.220	0.300	0.300	0.390	0.390	0.490	0.110	0.140	1.70	2.20		0.100	0.150	0.250
280	315	0.240	0.330	0.330	0.430	0.430	0.540	0.120	0.150	1.90	2.40		0.110	0.160	0.280
315	355	0.270	0.360	0.360	0.470	0.470	0.590	0.140	0.170	2.20	2.70		0.120	0.180	0.300
355	400	0.300	0.400	0.400	0.520	0.520	0.650	0.150	0.190	2.40	3.00		0.130	0.200	0.330

Note: Dimensions in mm.

Mounting of Self-Aligning Ball Bearings on an Adapter Sleeve

Axial Drive-Up Method

1. Before mounting, smear the thread and the side face of the nut with a molybdenum disulphide paste or similar lubricant.
2. Smear the shaft and outside diameter of sleeve with a light oil.
3. Open the sleeve slightly by inserting and twisting a screw driver into the slit in the sleeve and position the sleeve on the shaft.
4. Slide bearing, lockwasher and locknut onto sleeve and tighten nut with a 'C' spanner until all slackness is removed.
5. Measure distance from end tapered sleeve to the face of locknut or to the face of the inner ring and note the dimension.
6. From the chart note the required "axial drive up" and tighten the locknut until the bearing has moved the required distance up the taper of the sleeve indicated by the reduction or increase in the measured distance originally noted. If the original dimension was from the end of the tapered sleeve to the face of the locknut then the dimension will increase but if the measurement was from the end of the tapered sleeve to the face of the inner ring the dimension will be reduced.
7. A self-aligning ball bearing with normal clearance when adjusted correctly should rotate freely but should have some resistance to swivelling.
8. Align one tab on the lock washer with a slot in the locknut and bend it into the slot, if no tabs line up with the slots slightly tighten the locknut until one lines up. **Never back off the nut to line up the tab with the slot.**

Mounting of Self-Aligning Ball Bearings on an Adapter Sleeve

Tightening Angle Method

1. Before mounting, smear the thread and the side face of the nut with a molybdenum disulphide paste or similar lubricant.
2. Smear the shaft and outside diameter of sleeve with a light oil.
3. Open the sleeve slightly by inserting and twisting a screw driver into the slit in the sleeve and position the sleeve on the shaft.
4. Slide bearing, lockwasher and locknut onto sleeve and tighten nut with a 'C' spanner until all slackness is removed.
5. Tighten locknut through the required angle α , taken from chart, and then reposition the 'C' spanner to 180° from its original position and give it a sharp tap with the hammer to straighten the bearing on its seating.
6. A self-aligning ball bearing with normal clearance when adjusted correctly should rotate freely but should have some resistance to swivelling.
7. Align one tab on the lock washer with a slot in the locknut and bend it into the slot, if no tabs line up with the slots slightly tighten the locknut until one lines up. **Never back off the nut to line up the tab with the slot.**

Mounting of Double Row Self-Aligning Ball Bearings with 1:12 Tapered Bores on to Adapter Sleeves

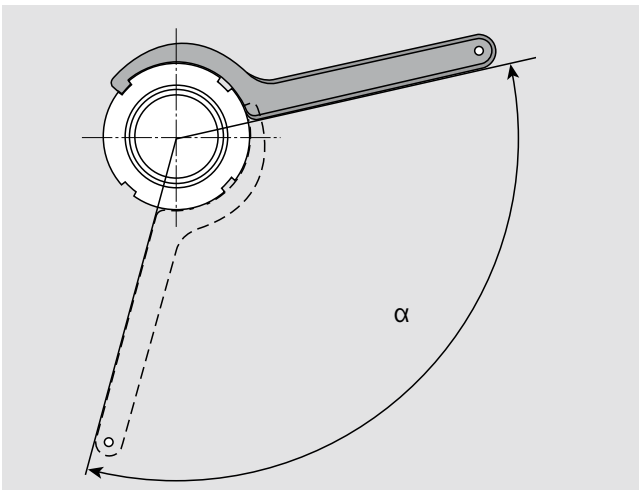

Bearing Bore Diameter mm		Tightening Angle (α) degrees	Approximate Axial Drive-Up mm
over	inclusive		
24	30	70	0.22
30	40	70	0.30
40	50	70	0.30
50	65	90	0.40
65	80	90	0.45
80	100	90	0.45
100	120	120	0.55
120	140	120	0.65
140	160	120	0.75

Mounting of SNN Plummer Blocks

using “G” Seals

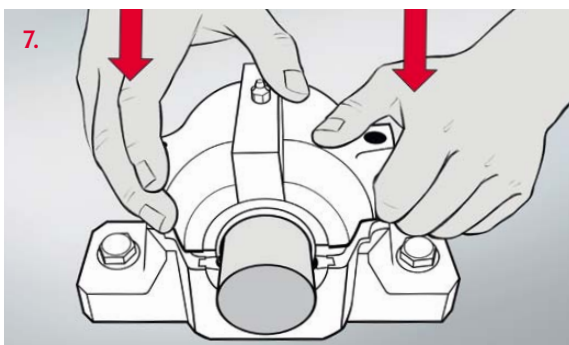
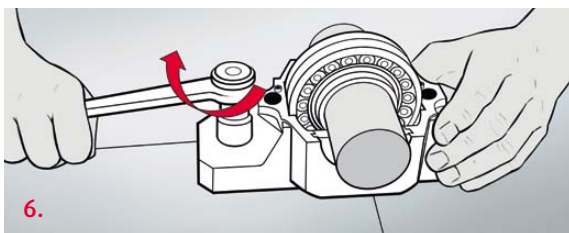
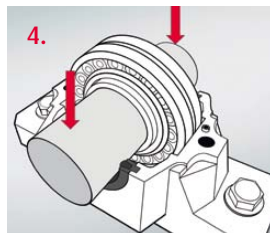
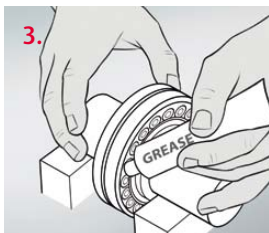
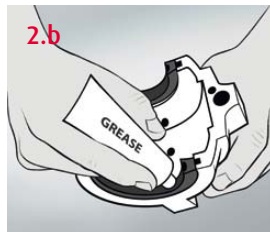
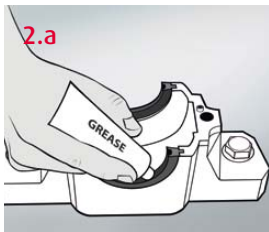
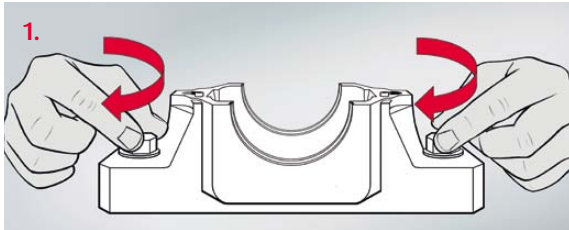

1. Place the housing base in position and hand tighten the fixing bolts.
2. Fit the seal halves into the seal grooves, in the base (a) and top (b) of the housings. Fill the section between the 2 lips of the seal with grease.
3. Mount the bearing on shaft and charge with grease.
4. Place the shaft and bearing assembly in the lower half of the split housing.
5. (Without picture) Insert the locating ring on both sides of the bearing (for fixed end).
6. Check housings alignment is correct and tighten the fixing bolts.
7. Assemble the housing cap over the base and tighten the cap bolts (recommended max. torque on page 10).

Before starting the plummer block installation, ensure that the environment is clean, and that the accuracies and tolerances of associated components are in accordance with the following recommendations:

Plummer block seating flatness:
IT7 to IT8, Ra max. 12.5 µm

Shaft: h9 IT5 to h10 IT7

Mounting of SNN Plummer Blocks

using "C" Seals

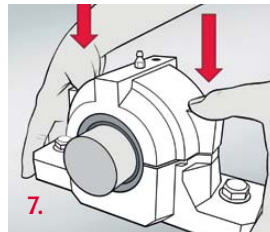
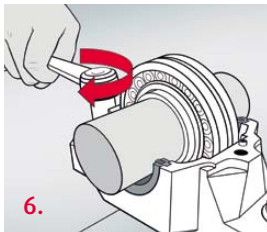
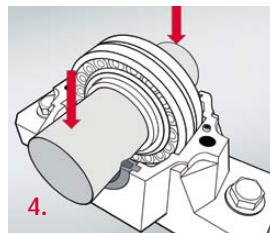
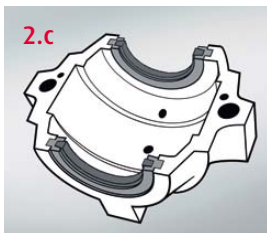
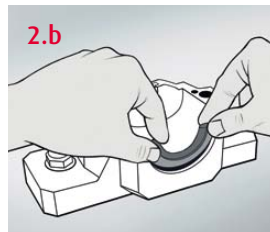
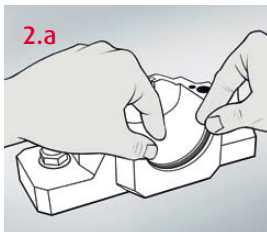
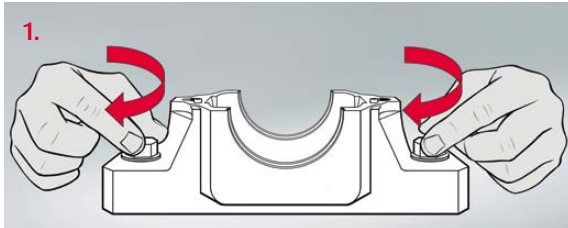

1. Place the housing base in position and hand tighten the fixing bolts.
2. Fit the nitrile rings (a) into the grooves in the base and cap (c) of the housing, followed by the steel adapters (b), containing the oil soaked felt strips.
3. Mount the bearing on shaft (detailed information on bearing fitting from page 22 to 26) and charge with grease.
4. Place the shaft and bearing assembly in the lower half of the housing.
5. (Without picture) Insert locating rings on both sides of the bearing (fixed end only).
6. Check housing alignment is correct and tighten the fixing bolts (recommended max. torque on page 10).
7. Assemble the housing cap and tighten the cap bolts (recommended max. torque on page 10).

Before starting the plummer block installation, ensure that the environment is clean, and that the accuracies and tolerances of associated components are in accordance with the following recommendations:

Plummer block seating flatness:
IT7 to IT8, Ra max. 12.5 µm

Shaft: h9 IT5 to h10 IT7

Mounting of SNN Plummer Blocks

using "V" Seals

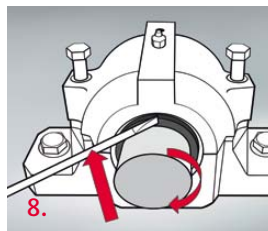
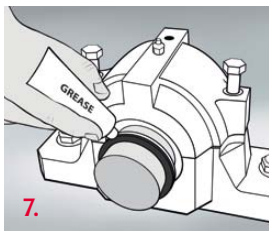
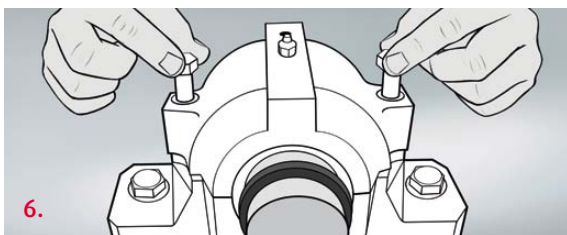
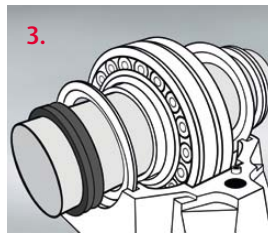
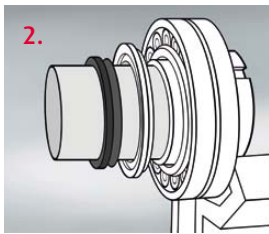
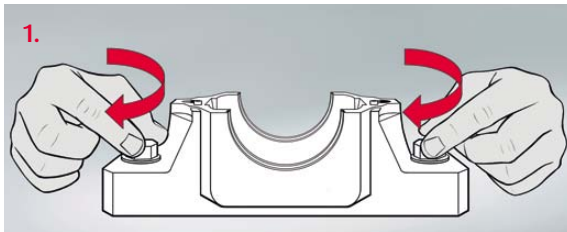

1. Place the housing base in position and hand tighten the fixing bolts.
2. Mount the bearing on shaft (detailed information on bearing fitting from page 22 to 26) and charge with grease. Place counterface washers and v-ring on shaft (shaft end side).
3. Place the shaft and bearing assembly in the lower half of the housing, aligning the counterface washers into the grooves.
4. (Without picture) Insert locating rings on both sides of the bearing (fixed end only).
5. Check housing alignment is correct and tighten the fixing bolts (recommended max. torque on page 10).
6. Assemble the housing cap and tighten the cap bolts (recommended max. torque on page 10).
7. Smear the surface of the counterface washers with grease to reduce friction.
8. While rotating the shaft, push the v-rings along the shaft into position.

Before starting the plummer block installation, ensure that the environment is clean, and that the accuracies and tolerances of associated components are in accordance with the following recommendations:

Plummer block seating flatness:
IT7 to IT8, Ra max. 12.5µm

Shaft: h9 IT5 to h10 IT7

Mounting of SNN Plummer Blocks

using “TS-U” Seals

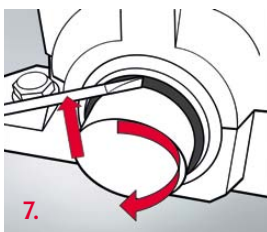
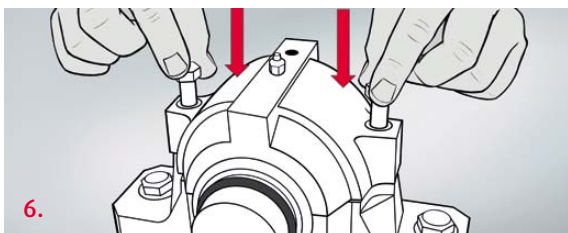
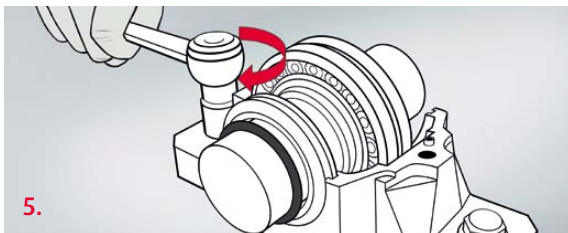
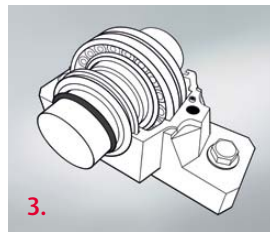
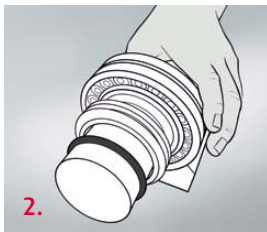
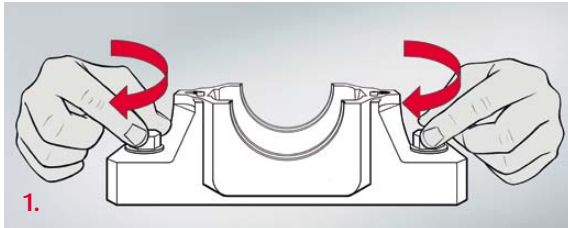

1. Place the housing base in position and hand tighten the fixing bolts.
2. Place the labyrinth on shaft (through shaft side). Mount the bearing on shaft (detailed information on bearing fitting from page 22 to 26) and charge with grease. Place the second labyrinth on shaft (shaft end side).
3. Place the shaft and bearing assembly in the lower half of the housing aligning the labyrinth into the grooves.
4. (Without picture) Insert the locating rings on both sides of the bearing (fixed end only).
5. Check housing alignment is correct and tighten the fixing bolts (recommended max. torque on page 10).
6. Assemble the housing cap and tighten the cap bolts (recommended max. torque on page 10).
7. While rotating the shaft, insert the o-rings into position.

Before starting the plummer block installation, ensure that the environment is clean, and that the accuracies and tolerances of associated components are in accordance with the following recommendations:

Plummer block seating flatness:
IT7 to IT8, Ra max. 12.5 μ m

Shaft: h9 IT5 to h10 IT7

Mounting of SNN Plummer Blocks

using "TACK" Seals

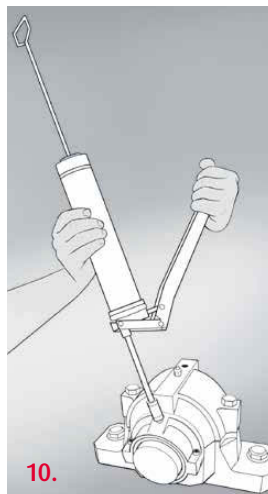
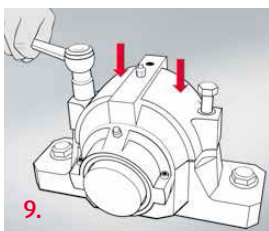
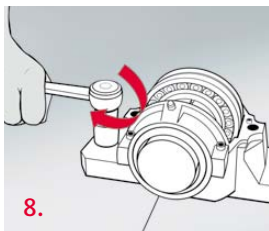
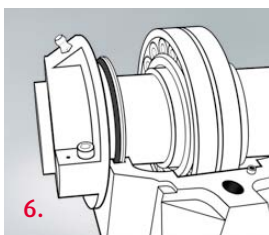
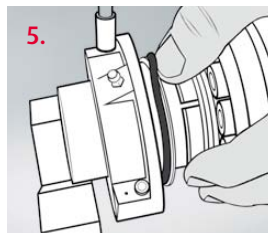
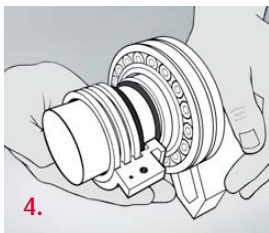
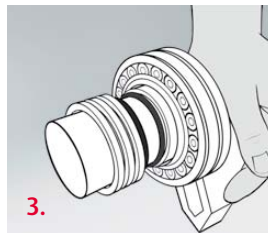
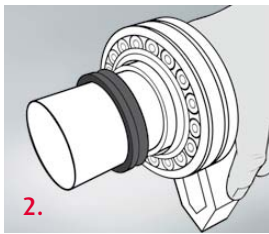
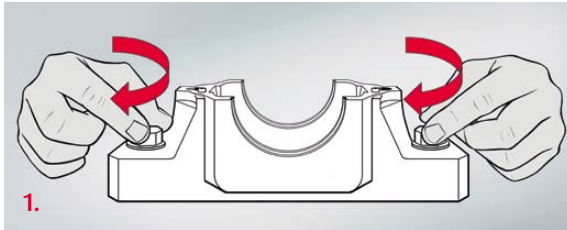

1. Place the housing base in position and hand tighten the fixing bolts.
2. Mount the v-ring (lip towards bearing) and labyrinth on shaft (through shaft side). Mount the split ring, covering the labyrinth and the v-ring. Tighten the split ring and insert the o-ring, fixing the labyrinth in position.
3. Mount the bearing on shaft (detailed information on bearing fitting from page 22 to 26) and charge with grease.
4. Fit the second seal on the shaft (shaft end side).
5. Mount the o-rings on each seal outer diameter.
6. Place the shaft and bearing assembly in the lower half of the housing, positioning the labyrinth in the grooves.
7. (Without picture) Insert locating rings on both sides of the bearing (fixed end only).
8. Check housing alignment is correct and tighten the fixing bolts (recommended max. torque on page 10).
9. Place the housing cap and tighten the cap bolts (recommended max. torque on page 10).
10. Before starting the machine, grease the seals while rotating the shaft until a small amount of grease oozes from the labyrinth rings.

Before starting the plummer block installation, ensure that the environment is clean, and that the accuracies and tolerances of associated components are in accordance with the following recommendations:

**Plummer block seating flatness:
IT7 to IT8, Ra max. 12.5 µm**

Shaft: h9 IT5 to h10 IT7

NSK Sales Offices – Europe, Middle East and Africa

UK

NSK UK Ltd.
Northern Road, Newark
Nottinghamshire NG24 2JF
Tel. +44 (0) 1636 605123
Fax +44 (0) 1636 643276
info-uk@nsk.com

France & Benelux

NSK France S.A.S.
Quartier de l'Europe
2, rue Georges Guynemer
78283 Guyancourt Cedex
Tel. +33 (0) 1 30573939
Fax +33 (0) 1 30570001
info-fr@nsk.com

Germany, Austria, Switzerland, Nordic

NSK Deutschland GmbH
Harkortstraße 15
40880 Ratingen
Tel. +49 (0) 2102 4810
Fax +49 (0) 2102 4812290
info-de@nsk.com

Italy

NSK Italia S.p.A.
Via Garibaldi, 215
20024 Garbagnate
Milanese (MI)
Tel. +39 02 995 191
Fax +39 02 990 25 778
info-it@nsk.com

Middle East

NSK Bearings Gulf Trading Co.
JAFZA View 19, Floor 24 Office 2/3
Jebel Ali Downtown,
PO Box 262163
Dubai, UAE
Tel. +971 (0) 4 804 8205
Fax +971 (0) 4 884 7227
info-me@nsk.com

Poland & CEE

NSK Polska Sp. z o.o.
Warsaw Branch
Ul. Migdałowa 4/73
02-796 Warszawa
Tel. +48 22 645 15 25
Fax +48 22 645 15 29
info-pl@nsk.com

Russia

NSK Polska Sp. z o.o.
Russian Branch
Office 1 703, Bldg 29,
18th Line of Vasilievskiy Ostrov,
Saint-Petersburg, 199178
Tel. +7 812 3325071
Fax +7 812 3325072
info-ru@nsk.com

South Africa

NSK South Africa (Pty) Ltd.
25 Galaxy Avenue
Linbro Business Park
Sandton 2146
Tel. +27 (011) 458 3600
Fax +27 (011) 458 3608
nsk-sa@nsk.com

Spain

NSK Spain, S.A.
C/ Tarragona, 161 Cuerpo Bajo
2ª Planta, 08014 Barcelona
Tel. +34 93 2892763
Fax +34 93 4335776
info-es@nsk.com

Turkey

NSK Rulmanları Orta Doğu Tic. Ltd. Şti
19 Mayıs Mah. Atatürk Cad.
Ulya Engin İş Merkezi No: 68/3 Kat. 6
P.K.: 34736 - Kozyatağı - İstanbul
Tel. +90 216 4777111
Fax +90 216 4777174
turkey@nsk.com

Please also visit our website: www.nskeurope.com
Global NSK: www.nsk.com

