

your global specialist

Special knowledge

Economical lubrication for every component.

Speciality lubricants for machine tools

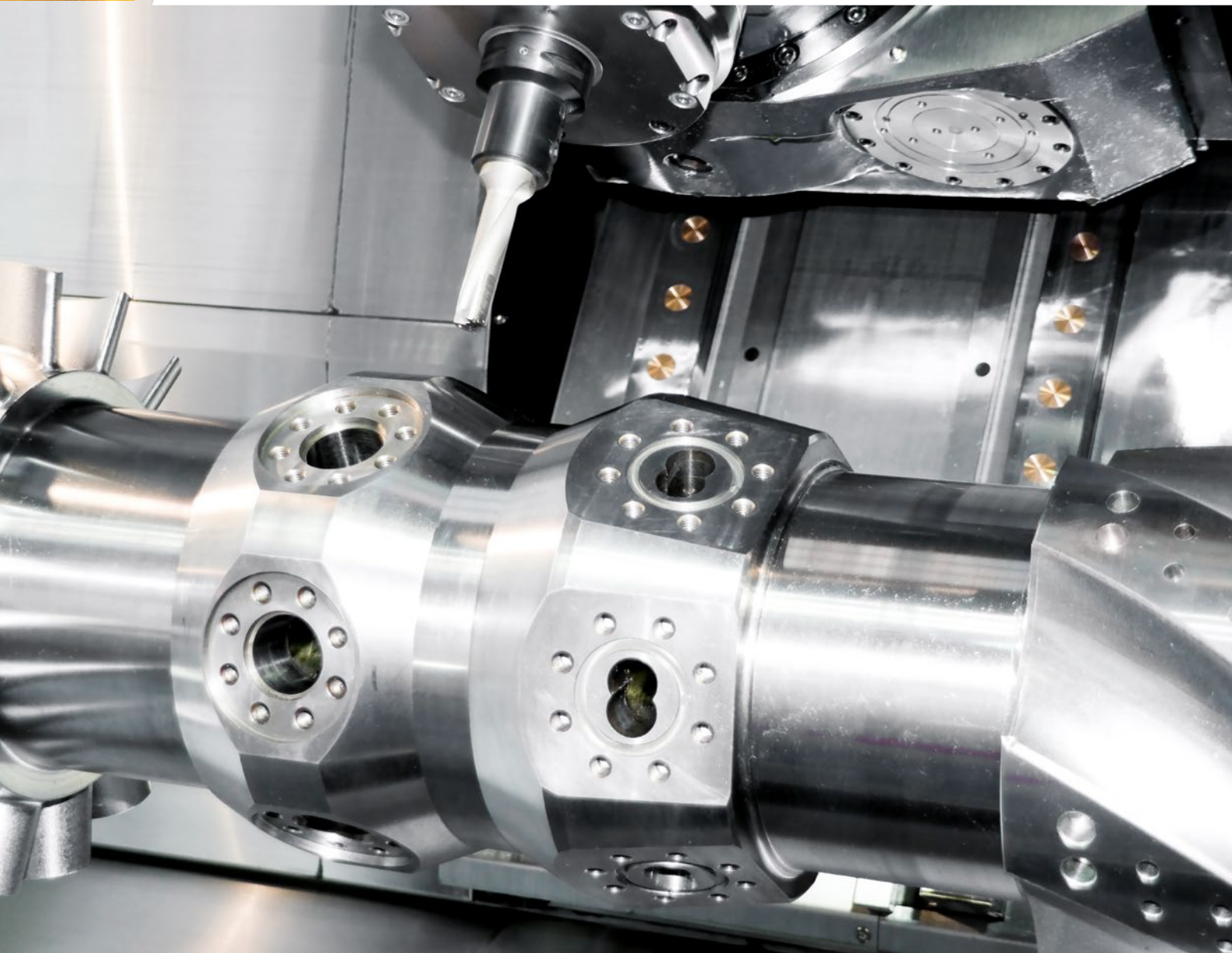



Think economics from the start

Klüber Lubrication has the right solution for manufacturers and operators of machine tools.

Think economics from the start	3
The lubrication of spindle bearings	4
The lubrication of work holding systems	6
The lubrication of drilling and milling head gear units	7
The lubrication of drive and guide systems	8
Greases for the lubrication of spindle	10
Oils for the lubrication of spindle bearings	12
Pastes for the lubrication of clamping devices	14
Greases for the lubrication of gears in drilling and milling heads	16
Corrosion protection	18
Greases for the lubrication of linear drive and guide systems	20
Oils for the lubrication of linear drive and guide systems	24

Make the right lubrication decision in the design phase

The machines you manufacture are expected to run efficiently, productively and reliably at all times. Klüber Lubrication supports you in meeting these requirements with lubricants suited to your needs. Benefit from our expertise during the machine design phase: the decisions you make during the development process determine about 70-85 % of the total machine life-cycle costs. Operators will appreciate it if you consider their expectations right from the start, including the right lubricant. We can offer you a product portfolio covering the complete range of operator requirements.

The lubricant is a crucial element for excellent machine tool performance and increased efficiency.

Speciality lubricants from Klüber Lubrication – most of them based on synthetic oils – will often not only lead to extended relubrication or oil change intervals, but even enable lifetime lubrication.

A test house that is unrivalled worldwide

When developing and testing our speciality lubricants we use the yardstick of your specific requirements. Our unique test house offers more than 100 different test rigs for use by our experts. Many of them were developed at Klüber Lubrication for your specific testing requirements.

We enhance the significance of our tests with accompanying lubricant and surface analyses of test pieces and component specimens. After all, we know how important it is for you that the lubricant demonstrates it will meet or even exceed requirements at the testing stage.

The question whether we should rely on tried and tested, reliable products, or venture into new territory is settled in personal discussions with our customers.

Economic and efficient operation

Operators have to find the best lubrication solution for their requirements if they want their machinery to be state-of-the-art in terms of lubrication engineering. We are happy to advise you on extended maintenance intervals, lifetimes of machine components or reduced external cost factors. If you have not used Klüber lubricants for your machine tools so far, our specialists will find a technically and economically convincing solution.

Global competence

We are where you are. Our specialists will advise you wherever it is convenient for you. Consultations may focus on the selection of a suitable product, or the development of a solution tailored to your requirements.

“Made by Klüber Lubrication” stands for consistent high quality level worldwide. We offer you products that are all made to the same high quality, no matter whether produced in Asia, Europe or the Americas.

The lubrication of spindle bearings

Machine tool main spindles running at higher speeds enable ever greater machining rates and shorter machining times per workpiece. These high speeds result in demanding operating conditions for rolling bearings. Spindle bearings are required to operate at high speed factors ($n \times dm$) and run with reduced

friction to keep bearing temperature low. The bearings have to carry both radial and axial loads. Naturally, premature bearing failure must be prevented.



Reliable at high speeds

ISOFLEX NBU 15 has been the yardstick for reliable machine tool spindle operation for decades. We have developed a new generation of high-speed greases, the Klüberspeed series, for speed factors up to $2,300,000 \text{ mm} \times \text{min}^{-1}$. Our lubricants are made to match precisely the requirements of the machine tool industry. They protect machine components effectively against corrosion to increase their

service life, not least due to their excellent adhesion. They are resistant to water and cutting fluids. We will be pleased to discuss and recommend the right lubricant from our product range whether you are dealing with speed factors below $600,000 \text{ mm} \times \text{min}^{-1}$ with high loads, or with those exceeding $2,300,000 \text{ mm} \times \text{min}^{-1}$ for high-speed machining.

Grease lubrication

There are now high-speed greases that can handle speeds previously only possible with oils. Speed factors of less than $1,000,000 \text{ mm} \times \text{min}^{-1}$ have not posed a problem with tried-and-tested Klüber Lubrication products for years.

With highly advanced special greases, even speed factors above $2,000,000 \text{ mm} \times \text{min}^{-1}$ can be accommodated. The advantage of grease lubrication is that it allows simpler machine design and easier assembly of the machine tool spindle. Our spindle bearing greases have proven to provide for-life lubrication in many practical applications.

Lubricating greases for high-speed rolling bearings are usually based on low-viscosity synthetic base oils with a variety of different thickeners.

Oil lubrication

For even higher speed factors, oil lubrication is often used. Oil-air lubrication is today most common. It is a minimum-quantity lubrication technique enabling extremely low oil consumption with tried-and-tested Klüber Lubrication products. It requires, however, the provision of compressed air, which incurs additional costs.

Experience has shown that a synthetic oil of viscosity class ISO VG 68 is best suitable for optimum results.

How to select the right lubricating grease

The speed factor ($n \times dm$)

The speed factor $n \times dm$ given for rolling bearings is given by the bearing speed n in [min^{-1} or rpm] and the mean bearing diameter dm in [mm]. The speed factor of a grease depends to a high degree on the base oil type, the base oil viscosity, the thickener and the type of rolling bearing to be lubricated.

Grease quantity

For lifetime lubrication, the grease quantity is determined by calculating the free bearing space. Spindle bearings should only be partly filled (for guidance: approx. 20 % of the free space, in extreme cases only up to approx. 10 %). As there are different designs of bearings and their cages, calculations of free bearing space will always be approximations.

Formula for calculating free bearing space acc. to work-sheet 3 by GfT (German Society for Tribology):

$$V \approx \left[\frac{\pi}{4} \times B \times (D^2 - d^2) \times 10^{-9} - \frac{G}{7800} \right] m^3$$

The following applies:

V = free bearing space, d = bearing bore diameter [mm]
 D = bearing outer diameter [mm], B = bearing width [mm]
 G = bearing weight [kg]

If you wish to determine the free bearing space with full accuracy, you will have to turn to the bearing manufacturer. Then you can calculate the corresponding grease volume as a percentage of the free bearing space with the diagram shown below.

Both excessive and insufficient lubrication can have negative operational effects: too much grease, for example, can lead to higher starting and running torque or, in high-speed bearings, to overheating.

The following should be observed:

Low operating temperature = long grease and bearing life
 High-speed greases should not run at more than $80 \text{ }^\circ\text{C}$ ($176 \text{ }^\circ\text{F}$).
 A bearing temperature of $40\text{--}50 \text{ }^\circ\text{C}$ ($104 \text{ }^\circ\text{F}\text{--}122 \text{ }^\circ\text{F}$) is desirable.

Grease distribution run

Running the bearings in is necessary for high-speed precision bearings to distribute the grease correctly. You can increase the performance of your bearings substantially by optimising grease distribution.

HINT:

Please make sure to observe any information on spindle running-in provided by the spindle or bearing manufacturers.

Where oil-air lubrication is used, cleanliness is also essential as any impurities can reduce bearing life.

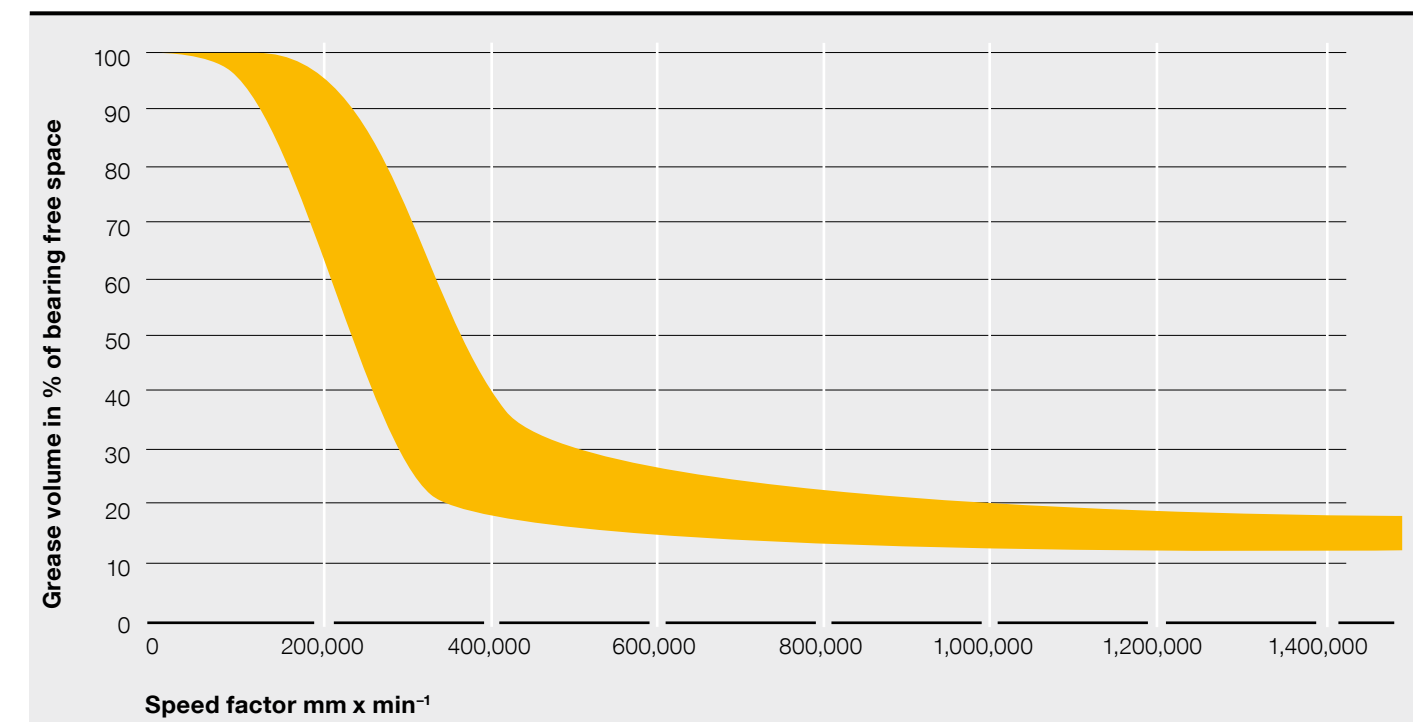

The yellow area shows the grease volume in % of the bearing free space as a function of the speed factor

The lubrication of work holding systems

It is important to make sure that the correct lubricant is chosen for lubrication of the work holding chuck. After all, the principal task is to generate a constant defined clamping force for a high number of clamping cycles. If the clamping force decreases, tools or workpieces may come loose. This applies to all types of chuck designs – scroll, cam or spiral chucks.

Lubricating pastes have proven very useful in these applications as they adhere well to the friction points and provide sufficient lubricity even when applied as a very thin film. Most pastes have low-viscosity base oils, a thickener and additional solid lubricant particles.

Tests performed with our pastes ALTEMP Q NB 50 and Klüberpaste ME 31-52 are proven to offer constant clamping forces over a large number of clamping tests, with low scatter of the results.

ALTEMP Q NB 50 and Klüberpaste ME 31-52 can also be used when installing friction connections such as annular springs and clamping sleeves, and positive connections such as bearing seats, profile guides, etc.

HINT:

Friction between the moving components of the clamping system can be reduced by applying just a thin layer of paste – just thick enough to cover the surface.

The lubrication of drilling and milling head gear units

Drilling and milling head gears play a major part in transmitting the substantial forces and torques from the machine tool main spindle to the cutting tool. They are operated cyclically. Some of them run at high peripheral speeds of more than 20 m/s.

The most important requirements to be met by these components are: reliable operation combined with long component life, high peripheral speeds and high acceleration. Most units incorporate spur, bevel or spiral bevel gears. We will be pleased to discuss with you optimised lubrication with you during the gearbox design stage. Depending on the individual technical requirements, different lubricants may prove preferable. Another aspect is that grease lubrication enables simpler designs than oil lubrication.

We offer you lubricants which

- are capable of dealing with strong acceleration and high peripheral speeds
- have good adhesion and pressure absorption capacity for good wear protection
- are resistant to water and cutting fluids for reliable operation
- offer effective corrosion protection for longer component life

In many cases, gear lubrication for drilling and milling heads will use the same grease as for spindle bearing lubrication since the bearings and gears normally share a common space. The use of the same or at least similar products offers the additional benefits of avoiding product confusion or lubricant incompatibility problems.

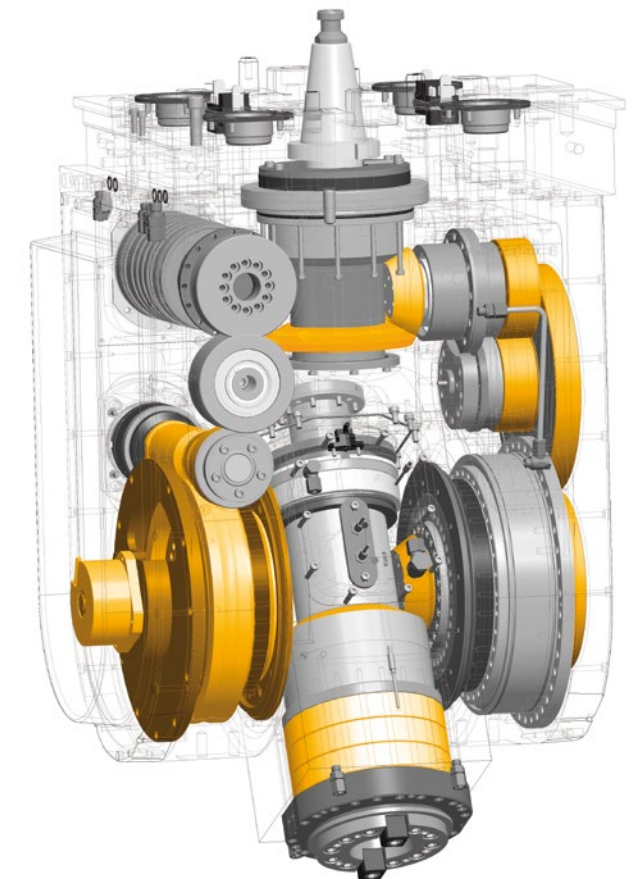

With lubricants made by Klüber Lubrication, you can lubricate various parts of milling head gear units

HINT:

Please remember to perform a grease distribution run and, if necessary, top up with lubricant. We would recommend using the same conditions as for the spindle bearings (page 4/5). The degree of grease filling is approximately 70 to 90 %, depending on the particular application. It is important to ensure that the grease does not exit from boreholes, gaps or similar apertures.

The lubrication of drive and guide systems

In most modern machine tools, workpieces and tools are positioned by means of antifriction guideways or slideways. They are normally moved by ball screws.

The specific requirements to be met by these components are taxing. They are expected to run with maximum precision, reliability and smoothness. They also have to cope with high speeds, acceleration and the resulting stresses.

The correct advanced speciality lubricants support your components in meeting these requirements. Speciality lubricants made by Klüber Lubrication protect against wear also when subject to micro-movements, and due to reduced friction they facilitate machine start-up. They provide high-performance corrosion protection, a good demulsifying ability, and a high resistance to media. In a contaminated environment, they provide additional sealing. They are compatible with most plastics and elastomers as well as with other lubricants. Finally, their good noise damping effect contributes to a healthier workplace.

We are happy to support you in selecting the matching lubricant for your drive and guide system.

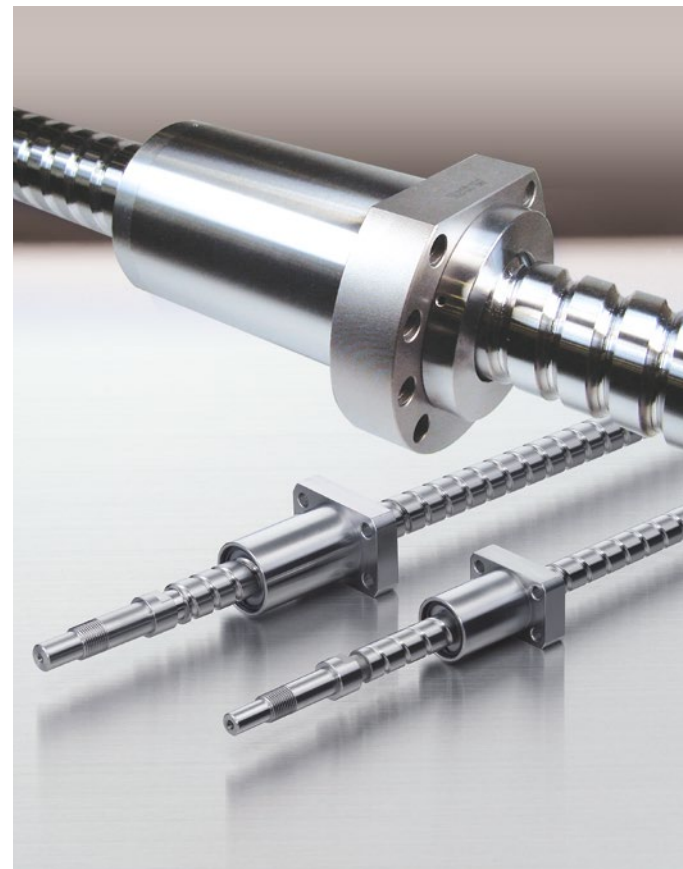

Klüber Lubrication offers the right lubricant for linear systems of different sizes

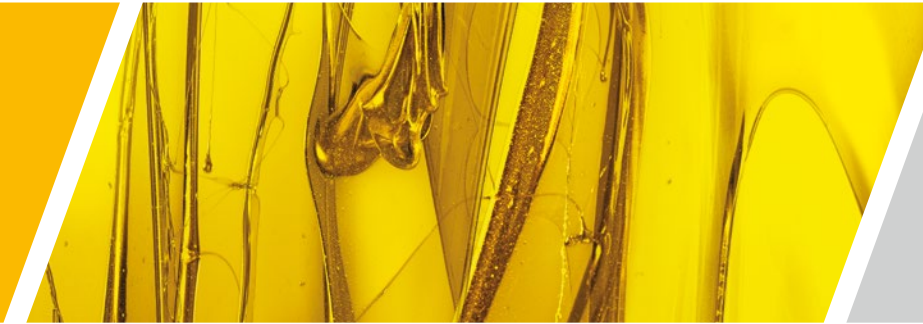

Speed-viscosity ratio

Speed	Speed	Speed
low	medium	HIGH
< 15 m/min vibration < 0.5 m/s ²	15 m/min to 60 m/min vibration < 1 m/s ²	> 60 m/min vibration < 2 m/s ²
↓	↓	↓
high viscosity (100 to 500 mm ² /s)	medium viscosity (approx. 100 mm ² /s)	low viscosity (25 to 70 mm ² /s)

Overview of tried-and-tested base oil viscosities for various linear speed conditions.

Each lubricant has a different composition selected to deal with varying complex requirements. Depending on the speeds and loads, different base oil viscosities are required. Different thickeners provide characteristics such as good adhesion to metal surfaces, good resistance or good damping. There are lubricants with suitable composition to match every type of application.

Initial greasing is normally provided by the OEM. Relubrication with a softer grease is then done by the operator, using centralised lubrication systems or lubricant dispensers. It is therefore vital that the lubricants used for initial lubrication and relubrication be compatible with one another.

Stick-slip between surfaces of guide systems is particularly likely at slow speeds, when starting or slowing down, and at high surface pressure. In these cases, friction forces are strongest and may lead to «chatter marks» on the machined workpiece. To prevent stick-slip, we developed the bonded coating WOLPASIT SECURO FLUID. As the solid lubricant particles contained in the coating are set in the surfaces of the guideways, the contact ratio is increased and friction reduced.

For optimum results, we recommend coating both friction surfaces. One litre is sufficient to coat a 50 m² surface area. Lubrication is even more effective when supplemented by high-quality LAMORA D slideway oils.

HINT:

We recommend cleaning the guideway or ball screw using a lint-free cloth.

The relubrication quantity is approx. 50 % of the initial lubricant volume. As a rule, it is better to relubricate more often, but with smaller quantities.



Greases for the lubrication of spindle



Application	Speed factor ¹⁾ n x d _m [min ⁻¹ x mm], approx.	Product	Base oil	Thickener	Corrosion protection (EMCOR test) DIN 51802	Worked penetration DIN ISO 2137 [0.1 mm]	Base oil viscosity DIN 51562 [mm ² /s] at 40 °C (104 °F), approx.	Base oil viscosity DIN 51562 [mm ² /s] at 100 °C (212 °F), approx.	Benefits and notes
Bearings in indirectly driven spindles									
Spindle bearings with medium speeds	600,000	ISOFLEX TOPAS NB 152	Synthetic hydrocarbon oil	Barium complex soap ²⁾	0	265 to 295	100	14.5	<ul style="list-style-type: none"> – Long component life due to high load-carrying capacity and corrosion protection – Long-term or for-life lubrication due to good resistance to water, cooling lubricants and ageing
Spindle bearings with high speeds	1,600,000	ISOFLEX NBU 15	Ester oil/ synthetic hydrocarbon oil/mineral oil	Barium complex soap ²⁾	≤ 1	265 to 295	21	4.5	<ul style="list-style-type: none"> – Long component life due to high load-carrying capacity and corrosion protection – Long-term or for-life lubrication due to good resistance to water, cooling lubricants and ageing – Tried and tested for many years, especially in angular contact ball bearings – Numerous OEM recommendations
Spindle bearings with very high speeds	2,000,000	Klüberspeed BF 72-22	Ester oil/ synthetic hydrocarbon oil	Polyurea	≤ 1	250 to 280	22	5	<ul style="list-style-type: none"> – Longer component life due to good corrosion protection, running-in properties and grease distribution in the bearing – Good water and ageing resistance – Especially for angular contact ball bearings
Spindle bearings with very high speeds	2,100,000	Klüberspeed BF 72-23	Ester oil/ synthetic hydrocarbon oil	Polyurea	≤ 1	220 to 250	22	5	<ul style="list-style-type: none"> – Longer component life due to good corrosion protection, running-in properties and grease distribution in the bearing – Good water and ageing resistance – Especially for angular contact ball bearings – High consistency, particularly for vertical mounting positions
Spindle bearings with very high speeds	2,300,000	Klüberspeed BFP 42-32	Ester oil	Lithium soap	≤ 1	250 to 280	30	6	<ul style="list-style-type: none"> – Longer component life due to good corrosion protection – Long-term or for-life lubrication due to good water resistance
Bearings in directly driven spindles									
Spindle bearings of motor spindles and/or high temperatures	2,000,000	Klüberquiet BQ 74-73 N	Ester oil/ synthetic hydrocarbon oil	Polyurea	≤ 1	220 to 250	60	9.5	<ul style="list-style-type: none"> – Wide service temperature range allows easy start even under difficult conditions – Longer component life due to good corrosion protection – For motor spindle bearings subject to elevated bearing temperatures, long-term or for-life lubrication – High consistency, particularly for vertical mounting positions

¹⁾ Speed factors are guide values which depend on the type and size of the rolling bearing type and the local operating conditions, which is why they have to be confirmed in tests carried out by the user in each individual case.

²⁾ Klüber barium complex soaps have been registered as ELINCS substances for many years and are REACH-registered already today, ensuring they are fit for the future. Upon toxicological analysis, the special soap was rated as not dangerous for human health and the environment.

Oils for the lubrication of spindle bearings



Application	Product	Base oil	Copper corrosion DIN EN ISO 2160, 24 h/100 °C (212 °F)	Viscosity DIN 51562 [mm ² /s] at 40 °C (104 °F), approx.	Viscosity DIN 51562 [mm ² /s] at 100 °C (212 °F), approx.	Benefits and notes
Spindle bearing oil	CONSTANT	Synthetic hydrocarbon oil	1–100	32	6.0	<ul style="list-style-type: none"> – Good load-carrying capacity ensures smooth running – Long component life due to good corrosion protection – Long component life due to low steady-state temperature of bearing – Low lubricant costs due to good resistance to oxidation and ageing
	OY 32 K		1–100	46	8.0	
	OY 46 K OY 68 K		1–100	68	10.5	
Spindle bearing oil	Klüber Summit	Synthetic hydrocarbon oil	1–100	15	3.5	<ul style="list-style-type: none"> – Low change in viscosity with alternating temperatures increases efficiency – Good environmental compatibility due to low evaporation rate – High process stability, e.g. due to good foaming behaviour and demulsifying ability
	HySyn FG 15		1–100	32	5.8	
	HySyn FG 32		1–100	46	7.7	
	HySyn FG 46 HySyn FG 68		1–100	68	10.4	

Application	Product	Base oil	Purity class, ISO 4406	Viscosity DIN 51562 [mm ² /s] at 40 °C (104 °F), approx.	Viscosity DIN 51562 [mm ² /s] at 100 °C (212 °F), approx.	Benefits and notes
Spindle bearing oil, ultra-fine filtered	Klübersynth	Synthetic hydrocarbon oil	15/13/10	32	6	<ul style="list-style-type: none"> – High oil purity: purity class 15/1310 acc. to ISO 4406 – Preferably for high-speed spindles (ISO VG 68 tested up to $n \times d_m = 2,5 \cdot 10^6$ mm/min)
	FB 4-32		15/13/10	46	7.6	
	FB 4-46 FB 4-68		15/13/10	68	9.6	

Pastes for the lubrication of clamping devices



Application	Product	Clamping force loss ¹⁾ [%]	Base oil	Thickener	Solid lubricant	Four-ball wear test, welding load DIN 51350 pt. 04 [N]	Corrosion protection (EMCOR test) DIN 51802	Worked penetration DIN ISO 2137 [0.1 mm]	Base oil viscosity DIN 51562 [mm ² /s] at 40 °C (104 °F), approx.	Base oil viscosity DIN 51562 [mm ² /s] at 100 °C (212 °F), approx.	Benefits and notes
Lubrication of work holding systems in machine tools	ALTEMP Q NB 50	< 15	Mineral oil	Barium complex soap ²⁾	Inorganic	> 4,000	≤ 1	250 to 270	46	7	<ul style="list-style-type: none"> – Improved economic efficiency of initial lubrication and relubrication due to good water- and media-resistance and hence long service life – Good wear and corrosion protection help to reduce assembly forces and screw torques and prevent tribo- and fretting corrosion – High pressure absorption capacity enables constant clamping forces and consequently ensures properly fixed tools or workpieces in machine tool chucks
Lubrication of work holding systems in machine tools	Klüberpaste ME 31-52	< 10	Mineral oil	Calcium complex soap	Inorganic	> 4,000	≤ 1	250 to 280	46	–	<ul style="list-style-type: none"> – Reduced lubricant costs for initial and relubrication due to thin-film application – Good wear and corrosion protection help to reduce assembly forces and screw torques and prevent tribo- and fretting corrosion – High pressure absorption capacity enables constant clamping forces and consequently ensures properly fixed tools or workpieces in machine tool chucks

¹⁾ Clamping force block KSP 160, 6 bar

²⁾ Klüber barium complex soaps have been registered as ELINCS substances for many years and are REACH-registered already today, ensuring they are fit for the future. Upon toxicological analysis, the special soap was rated as not dangerous for human health and the environment.

Greases for the lubrication of gears in drilling and milling heads



Application	Load-dependent max. circumferential speed in intermittent operation [m/s]	Product	Base oil	Thickener	Corrosion protection (EMCOR test) DIN 51802	Worked penetration DIN ISO 2137 [0.1 mm]	Base oil viscosity DIN 51562 [mm ² /s] at 40 °C (104 °F), approx.	Base oil viscosity DIN 51562 [mm ² /s] at 100 °C (212 °F), approx	Benefits and notes
Grease lubrication of gears in drilling and milling heads	< 4	Klübersynth G 34-130	Ester oil / synthetic hydrocarbon oil / mineral oil	Special calcium soap / polyurea	≤ 1	355 to 385	130	16	<ul style="list-style-type: none"> – Good protection against corrosion for long component life – Good resistance to water and ageing, long-term lubrication – Low consistency allows application by means of automatic metering systems
Grease lubrication of gears in drilling and milling heads	< 8	Klübersynth GE 46-1200	Polyalkylene glycol	Lithium soap	≤ 1	400 to 430	120	20	<ul style="list-style-type: none"> – Longer component life due to good load-carrying capacity – Longer component life due to good wear protection (FZG > 12) – Low consistency allows application by means of automatic metering systems, e.g. for spiral bevel gears
Grease lubrication of gears in drilling and milling heads	< 20	ISOFLEX NBU 15	Ester oil / synthetic hydrocarbon oil / mineral oil	Barium complex soap ¹⁾	≤ 1	265 to 295	21	4.5	<ul style="list-style-type: none"> – Longer component life due to good load-carrying capacity – Good resistance to water and ageing, long-term lubrication – Tried and tested for many years
Grease lubrication of gears in drilling and milling heads	> 20	ISOFLEX TOPAS NB 52	Synthetic hydrocarbon oil	Barium complex soap ¹⁾	0	265 to 295	30	6	<ul style="list-style-type: none"> – Longer component life due to good load-carrying capacity and corrosion protection – Good resistance to water and ageing, long-term or for-life lubrication
Grease lubrication of gears in drilling and milling heads	> 20	ISOFLEX TOPAS NB 5051	Synthetic hydrocarbon oil	Barium complex soap ¹⁾	≤ 1	385 to 415	30	6	<ul style="list-style-type: none"> – Dynamically light grease for high accelerations, e.g. for spiral bevel gears – Longer component life due to corrosion protection – Good resistance to water and ageing, long-term or for-life lubrication
Grease lubrication of gears in drilling and milling heads	> 20	Klüberspeed BF 72-22	Ester oil / synthetic hydrocarbon oil	Polyurea	≤ 1	250 to 280	22	5	<ul style="list-style-type: none"> – Longer component life due to good corrosion protection, running-in properties and good grease distribution in the gear – Good resistance to water and ageing, long-term lubrication

¹⁾ Klüber barium complex soaps have been registered as ELINCS substances for many years and are REACH-registered already today, ensuring they are fit for the future. Upon toxicological analysis, the special soap was rated as not dangerous for human health and the environment.

As the gears of drilling and milling heads can be lubricated with the same grease as the spindle bearing, gear lubrication is an additional application of these products which may not be explicitly mentioned in the product information leaflet.

Corrosion protection



Anticorrosion fluid for gears in drilling and milling heads

Application	Product	Corrosion protection properties of oils DIN ISO 7120, steel 24 h/60 °C (140 °F)	Base oil	Thickener	Benefits and notes
Corrosion protection of gears in milling and drilling heads as well as other metal surfaces	Klübersynth BZ 44-4000	No rust	Synthetic hydrocarbon oil/mineral oil	Lithium soap	<ul style="list-style-type: none"> - Longer component life due to good resistance to water and corrosion protection - Compatible with many lubricating greases - Increases the corrosion protection properties of lubricating greases

Anticorrosion oil

Application	Product	Fog test, FTMS 791C-4001.3, NaCl solution 5 %, 35 °C (95 °F)/72 h, based on DIN 51358, Degree of corrosion	Base oil	Kinematic viscosity, DIN 51562 pt. 01, [mm ² /s] at 40 °C (104 °F), approx.	Benefits and notes
Machines, installations, components	Klübersynth MZ 4-17	≤ 1	Synthetic hydrocarbon oil/ester oil	20	<ul style="list-style-type: none"> - Good corrosion protection, also when exposed to salt water - No residue formation, no gumming - Free from solvents - Compatible with lubricants, also suitable for initial lubrication, e.g. in linear guides - Also available as spray

Greases for the lubrication of linear drive and guide systems



Application	Linear speed [m/min]	Product	Base oil	Thickener	Worked penetration DIN ISO 2137 [0.1 mm]	Base oil viscosity DIN 51562 [mm ² /s] at 40 °C (104 °F), approx.	Base oil viscosity DIN 51562 [mm ² /s] at 100 °C (212 °F), approx.	Benefits and notes
Initial lubrication	< 15	MICROLUBE GL 262	Mineral oil	Special lithium soap	265 to 295	280	20	<ul style="list-style-type: none"> - Especially for high loads and vibrations - Long relubrication intervals due to good wear protection - Higher consistency for vertical mounting positions. - For relubrication MICROLUBE GL 261 with a softer consistency - Relubrication via grease nipple/grease gun
Initial lubrication	15 – 60	Klüberplex BEM 34-132	Synthetic hydrocarbon oil/ mineral oil	Special calcium soap	265 to 295	130	16	<ul style="list-style-type: none"> - Longer component life due to very good tribocorrosion protection, even when exposed to micro-movements - Long relubrication intervals due to good wear protection - Longer service life due to good media resistance - Relubrication via grease nipple/grease gun
Initial lubrication	15 – 60	Klüberplex BE 31-102	Mineral oil	Special calcium soap	265 to 295	100	12	<ul style="list-style-type: none"> - Tried and tested for many years - Longer component life due to good wear protection and media resistance - Longer service life due to good sealing effect and adhesion - Relubrication via grease nipple/grease gun
Initial lubrication	> 60	ISOFLEX NBU 15	Ester oil/ synthetic hydrocarbon oil/ mineral oil	Barium complex soap ¹⁾	265 to 295	21	4.5	<ul style="list-style-type: none"> - Smooth running effect even under difficult conditions, therefore lower increase of temperature - Longer component life due to good protection against wear and corrosion - Longer service life due to high resistance to water and cooling lubricants - Product streamlining because also suitable for spindle bearings, gears in drilling and milling heads - Relubrication via grease nipple/grease gun

¹⁾ Klüber barium complex soaps have been registered as ELINCS substances for many years and are REACH-registered already today, ensuring they are fit for the future. Upon toxicological analysis, the special soap was rated as not dangerous for human health and the environment

Greases for the lubrication of linear drive and guide systems



Application / requirement	Linear speed [m/min]	Product	Base oil	Thickener	Worked penetration DIN ISO 2137 [0.1 mm]	Base oil viscosity DIN 51562 [mm ² /s] at 40 °C (104 °F), approx.	Base oil viscosity DIN 51562 [mm ² /s] at 100 °C (212 °F), approx.	Benefits and notes
Relubrication via central lubrication systems/lubricant dispenser	< 15	MICROLUBE GL 261	Mineral oil	Special lithium soap	310 to 340	290	20	<ul style="list-style-type: none"> - Longer service life due to very good wear protection - For high loads or micro-movements - Also for initial lubrication
Relubrication via central lubrication systems/lubricant dispenser	< 15	Klüberlub BE 71-501	Mineral oil	Polyurea/solid lubricant	310 to 340	490	32	<ul style="list-style-type: none"> - Longer service life due to very good wear protection - For high loads or micro-movements - Also for initial lubrication
Relubrication via central lubrication systems/lubricant dispenser	< 15	MICROLUBE GB 0 MICROLUBE GB 00	Mineral oil	Lithium soap/silicate	355 to 385 430 to 475	590 (calculated) 700 (calculated)	31.5 (calculated) 35 (calculated)	<ul style="list-style-type: none"> - Longer service life due to very good wear protection - For high loads or micro-movements - Also for initial lubrication
Relubrication via central lubrication systems/lubricant dispenser	15–60	Klüberplex BEM 41-141	Synthetic hydrocarbon oil/mineral oil	Special lithium soap	310 to 340	130	14	<ul style="list-style-type: none"> - Long service life due to good ageing resistance - Longer service life due to good wear protection, even when exposed to vibrations - Longer availability due to good corrosion protection - Also for initial lubrication
Relubrication via central lubrication systems/lubricant dispenser	> 60	ISOFLEX TOPAS NB 5051	Synthetic hydrocarbon oil	Barium complex soap ¹⁾	385 to 415	30	6	<ul style="list-style-type: none"> - Smooth running even under difficult conditions, therefore lower increase of temperature - Longer component life due to good corrosion and wear protection - Longer service life due to good adhesion as well as resistance to water and cooling lubricants - Also for initial lubrication

¹⁾ Klüber barium complex soaps have been registered as ELINCS substances for many years and are REACH-registered already today, ensuring they are fit for the future. Upon toxicological analysis, the special soap was rated as not dangerous for human health and the environment.

Oils for the lubrication of linear drive and guide systems

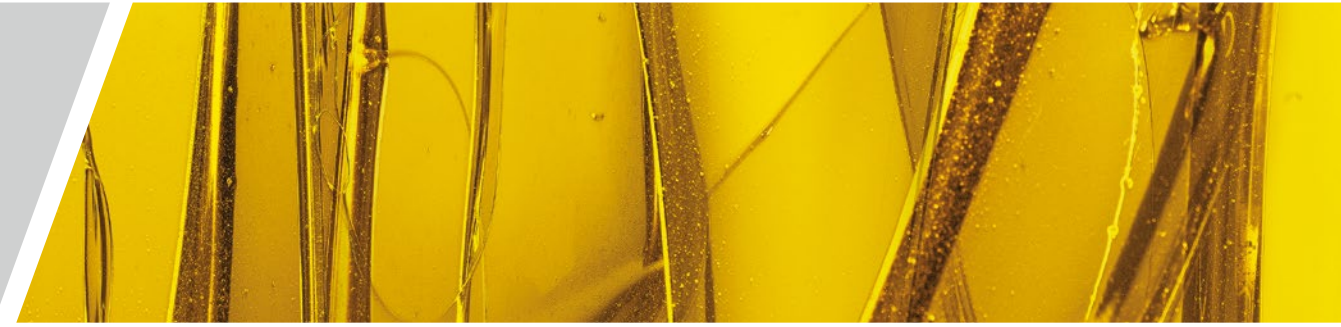

Oil lubrication for continuous lubrication

Application	Product	Base oil	ISO viscosity grade, DIN 51562 pt. 01, ISO VG	Benefits and notes
Antifriction guideways	Klüberoil GEM 1-68 N GEM 1-100 N GEM 1-220 N	Mineral oil	68 100 220	<ul style="list-style-type: none"> - CLP gear oils with good wear and corrosion protection - Viscosity depending on speed
Slideways	LAMORA D 68 D 220	Mineral oil	68 220	<ul style="list-style-type: none"> - CGLP slideway oils with good demulsifying effect on cooling lubricants, also proven for plastic guideways - Viscosity depending on speed

Bonded coating for guideways

Application	Product	Description	Density, DIN EN ISO 2811, 20 °C (68 °F), approx. [g/cm³]	Yield with a coating thickness of 10 µm, [m²/l]	Benefits and notes
Guideways	WOLPASIT SECURO FLUID	Air-drying, inorganic bonded coating	1.12	50	<ul style="list-style-type: none"> - Improves the sliding behaviour in the mixed-friction regime - Prevents stick-slip, especially when starting up or slowing down - Improves emergency lubricating properties - For steel and grey cast iron surfaces - Lubrication is even more effective when supplemented by slideway oils

Notes

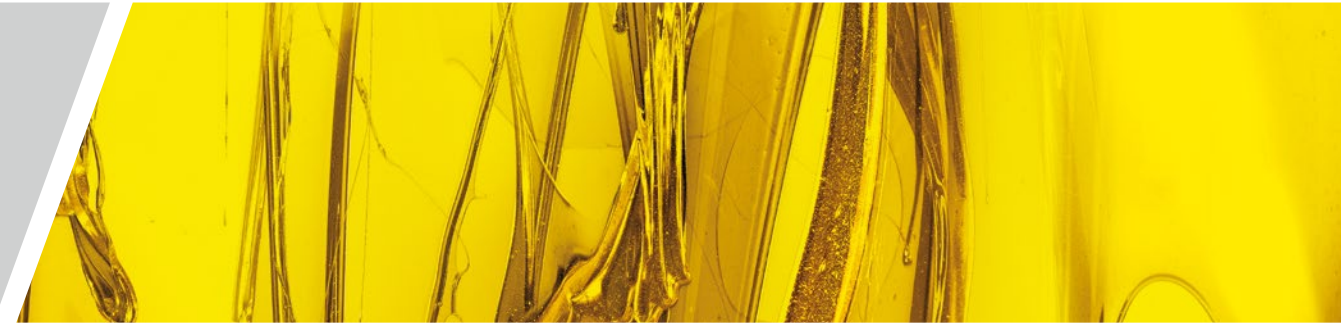

Publisher and Copyright:
Klüber Lubrication München SE & Co. KG

Reprints, total or in part, are permitted only prior consultation with Klüber Lubrication München SE & Co. KG and if source is indicated and voucher copy is forwarded.

The data in this document is based on our general experience and knowledge at the time of publication and is intended to give information of possible applications to a reader with technical experience. It constitutes neither an assurance of product properties nor does it release the user from the obligation of performing preliminary field tests with the product selected for a specific application. All data are guide values which depend on the lubricant's composition, the intended use and the application method. The technical values of lubricants change depending on the mechanical, dynamical, chemical and thermal loads, time and pressure. These changes may affect the function of a component. We recommend contacting us to discuss your specific application. If possible we will be pleased to provide a sample for testing on request. Products from Klüber Lubrication are continually improved. Therefore, Klüber Lubrication reserves the right to change all the technical data in this document at any time without notice.

Klüber Lubrication München SE & Co. KG
Geisenhausenerstraße 7
81379 München
Germany

Local first-instance court Munich, Germany
Certificate of registration 46624

www.klueber.com

Klüber Lubrication – your global specialist

Innovative tribological solutions are our passion. Through personal contact and consultation, we help our customers to be successful worldwide, in all industries and markets. With our ambitious technical concepts and experienced, competent staff we have been fulfilling increasingly demanding requirements by manufacturing efficient high-performance lubricants for more than 80 years.

